

TMF8701

Time-of-Flight Sensor

General Description

The TMF8701 is a time-of-flight (TOF) sensor in a single modular package with associated VCSEL. The TOF device is based on SPAD, TDC and histogram technology.

Ordering Information and Content Guide appear at end of datasheet.

Key Benefits & Features

The benefits and features of TMF8701, Time-of-Flight Sensor are listed below:

Figure 1:
Added Value of Using TMF8701

Benefits	Feature
<ul style="list-style-type: none"> Modular package - 2.2mm x 3.6mm x 1.0mm 	<ul style="list-style-type: none"> Small footprint fits in the mobile phone bezel
<ul style="list-style-type: none"> 21° FOI 	<ul style="list-style-type: none"> Detecting central closest objects
<ul style="list-style-type: none"> Time-to-Digital converter (TDC) Direct time-of-flight measurement 	<ul style="list-style-type: none"> Within 5% of measurement (accuracy); no multi-path and no multiple object problems as for iToF
<ul style="list-style-type: none"> Single Photon Avalanche Photodiode (SPAD) Histogram based architecture 	<ul style="list-style-type: none"> Better accuracy detects reliably closest object Min. distance 1mm (black target) Max. distance 60cm
<ul style="list-style-type: none"> Dynamic cover glass calibration 	<ul style="list-style-type: none"> No complex calibration
<ul style="list-style-type: none"> Reliable operation under demanding use cases 	<ul style="list-style-type: none"> Compensates for dirt on glass
<ul style="list-style-type: none"> Reference SPAD 	<ul style="list-style-type: none"> Improved accuracy over temperature and life
<ul style="list-style-type: none"> Distance and signal quality reported 	<ul style="list-style-type: none"> Make better decisions
<ul style="list-style-type: none"> Fast VCSEL driver with protection 	<ul style="list-style-type: none"> Class 1 Eye Safe
<ul style="list-style-type: none"> 940µA power consumption at 10Hz (proximity mode) 26mA power consumption at 60Hz operation (distance and proximity mode) 0.26µA power-down current consumption (EN=0) 	<ul style="list-style-type: none"> Longer battery life

Applications

The device is ideal for use in the mobile phone market with applications including:

- Distance measurement for camera autofocus (Laser Detect Autofocus - LDAF)
- Supporting low-power system operation by enabling high-power components (i.e. 3D facial recognition) only when an object is in the detection range
- Proximity detection
- Presence detection - Object detection
- Collision avoidance

Block Diagram

The functional blocks of this device are shown below:

Figure 2:
TMF8701 Block Diagram

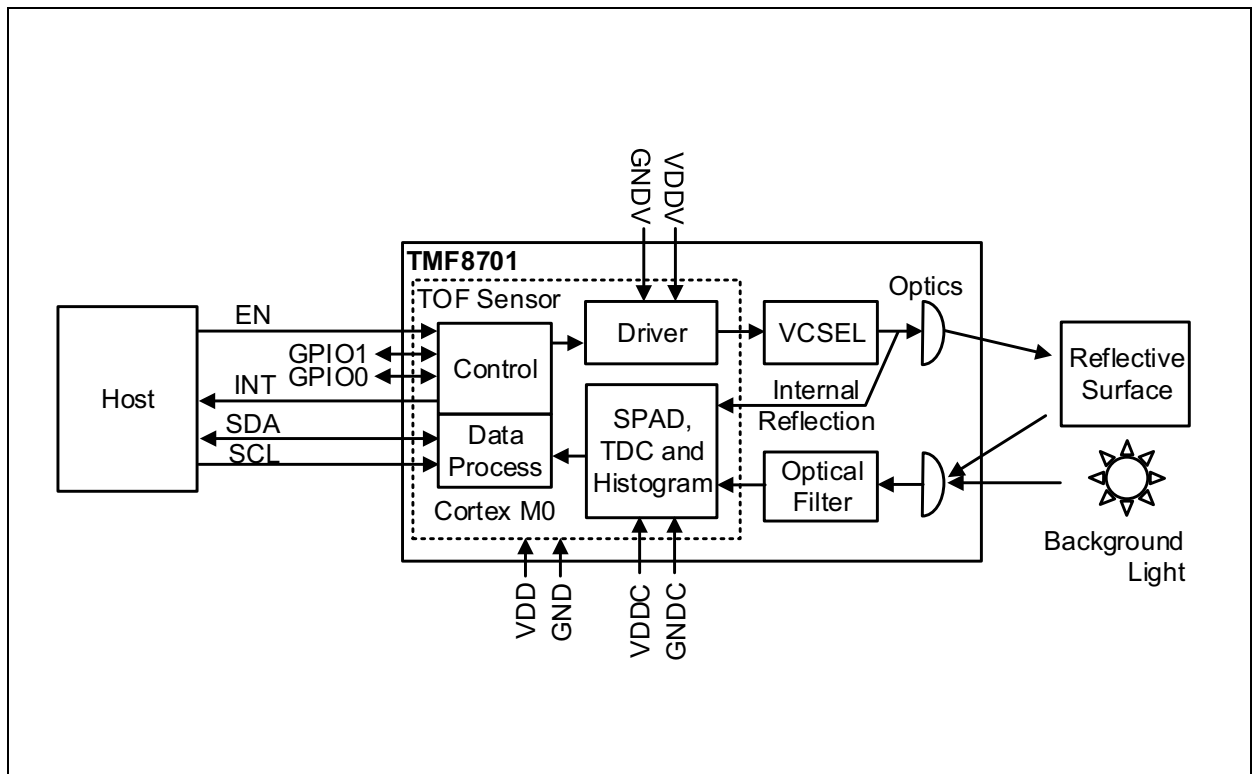

Pin Assignments

Pin Diagram

Figure 3:
Pin Diagram TMF8701 Module

Pin Diagram TMF8701 Module: Top through view (not to scale)

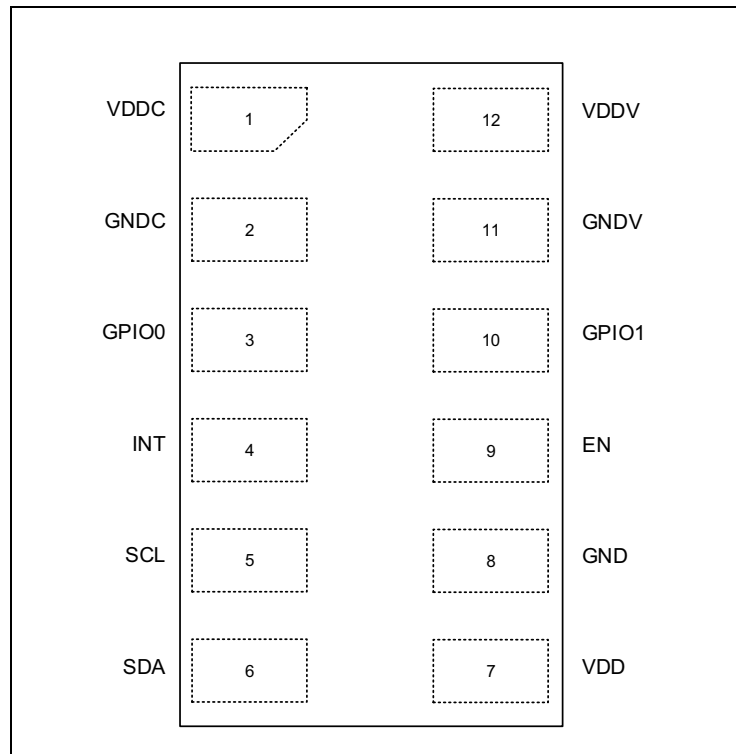

Pin Description

The GPIO is controlled by the firmware.

Figure 4:
Pin Description TMF8701 Module

Pin No.	Pin Name	Signal Type	Description
1	VDDC	Supply	Charge pump supply voltage (3V); add a capacitor GRM155R70J104KA01 (0402 X7R 0.1µF 6.3V) to GND
2	GNDC	Ground	Charge pump ground; connect all ground pins together
3	GPIO0	I/O	General purpose input/output; default output low; leave open if not used
4	INT	Output	Interrupt. Open-drain output; connect to GND if not used
5	SCL	Input	I ² C serial clock

Pin No.	Pin Name	Signal Type	Description
6	SDA	I/O	I ² C serial data
7	VDD	Supply	Chip supply voltage (3V); add a capacitor GRM155R70J104KA01 (0402 X7R 0.1μF 6.3V) to GND
8	GND	Ground	Chip ground; connect all ground pins together
9	EN	Input	Enable input active high; setting to low forces the device into shutdown and all memory content is lost; connect to VDD if not used
10	GPIO1	I/O	General purpose input/output; default output low; leave open if not used
11	GNDV	Ground	VCSEL ground; connect all ground pins together
12	VDDV	Supply	VCSEL supply voltage (3V); add a capacitor GRM155R70J104KA01 (0402 X7R 0.1μF 6.3V) to GND

Note(s):

1. SDA, SCL, INT and EN have no diode to any VDD supply. Therefore even with VDD=0V they do not block the interrupt line or I²C bus.
2. GPIO0 and GPIO1 are push/pull output and have a diode to VDD; therefore if VDD is not powered, GPIO0 and GPIO1 should not be driven from outside.

Absolute Maximum Ratings

Stresses beyond those listed under Absolute Maximum Ratings may cause permanent damage to the device. These are stress ratings only. Functional operation of the device at these or any other conditions beyond those indicated under Electrical Specifications is not implied. Exposure to absolute maximum rating conditions for extended periods may affect device reliability.

Figure 5:
Absolute Maximum Ratings TMF8701 Module

Symbol	Parameter	Min	Max	Units	Comment
VDDC, VDDV, VDD	3V Supply voltage	-0.3	3.6	V	Connect pins VDDC, VDDV, VDD on PCB with very short connections
GNDV, GNDC, GND	Ground	0.0	0.0	V	Connect all GND pins on PCB with very short connections
GPIO0, GPIO1	Digital I/O terminal voltage	-0.3	VDD+0.3V	V	Protection diode to VDD
INT, SCL, SDA, EN	Digital I/O terminal voltage	-0.3	3.6	V	No protection diodes to any positive supply only to ground
I_SCR	Latch-up immunity	±100		mA	JEDEC JESD78D Nov 2011
Electrostatic Discharge					
ESD_HBM	Electrostatic discharge HBM	±2000		V	JS-001-2014
ESD_CDM	Electrostatic discharge CDM	±500		V	JEDEC JESD22-C101F Oct 2013

Symbol	Parameter	Min	Max	Units	Comment
Temperature Ranges and Storage Conditions					
T_{STRG}	Storage Temperature	-40	85	°C	
RH_{NC}	Relative Humidity (non-condensing)		85	%	
T_{BODY}	Package Body Temperature		260	°C	IPC/JEDEC J-STD-020 ⁽¹⁾
MSL	Moisture Sensitivity Level	3			Represents a maximum floor life time of 168h with $T_{AMB} < 30^{\circ}C$ and $< 60\%$ r.h.

Note(s):

1. The reflow peak soldering temperature (body temperature) is specified according to IPC/JEDEC J-STD-020 "Moisture/Reflow Sensitivity Classification for Non hermetic Solid State Surface Mount Devices."

Electrical Characteristics

Recommended Operating Conditions

Device parameters are guaranteed at nominal conditions otherwise noted. While the device is operational across the temperature range, functionality will vary with temperature.

Figure 6:
Recommended Operating Conditions TMF8701 Module

	Parameter	Min	Typ	Max	Units	Comment
VDDV, VDDC, VDD	3V Supply voltage	2.7	3	3.3	V	
Temperature Range	Free-air temperature	-30	25	70	°C	Operational

Typical Operating Characteristics

Following operating characteristics are measured with calibrated devices with a full optical stack including glass and IR ink with >90% transmissivity. The airgap is set to 0.38mm. The ambient light is measured on the target. As target object a grey card with 20cm x 26cm is used.

Figure 7:
350Lux Fluorescent Light

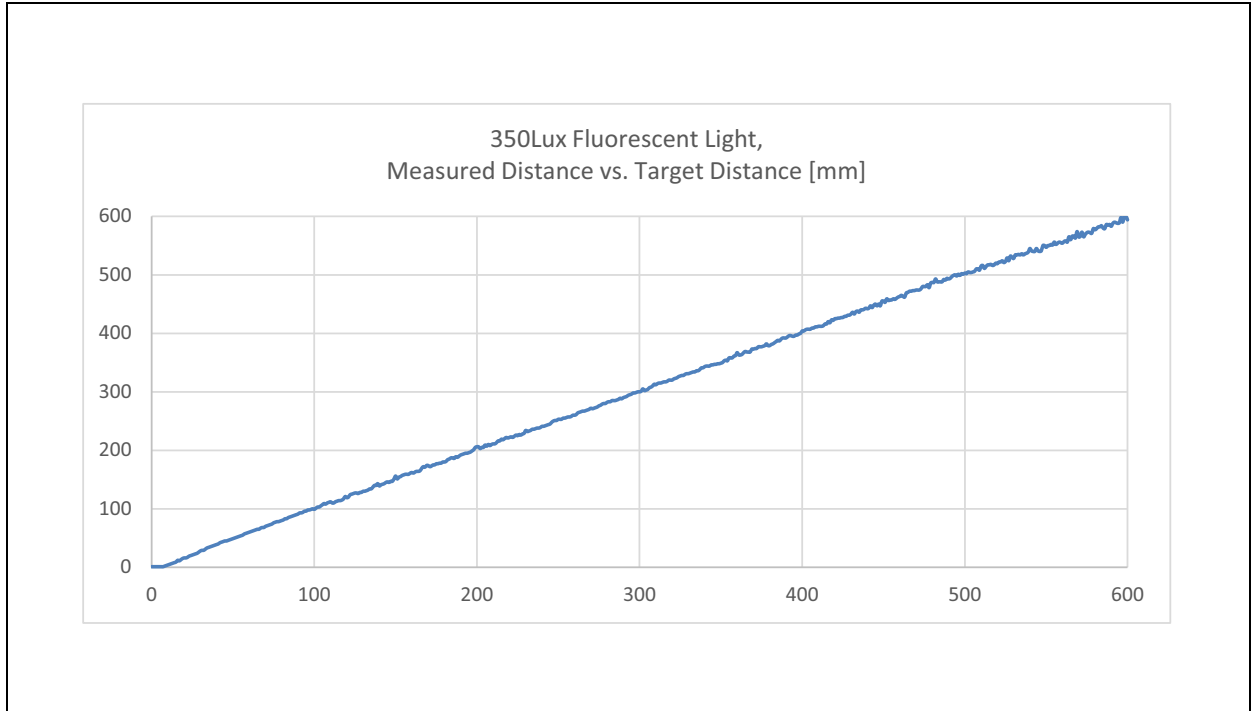

Figure 8:
350Lux Fluorescent Light (Smudge on Glass)

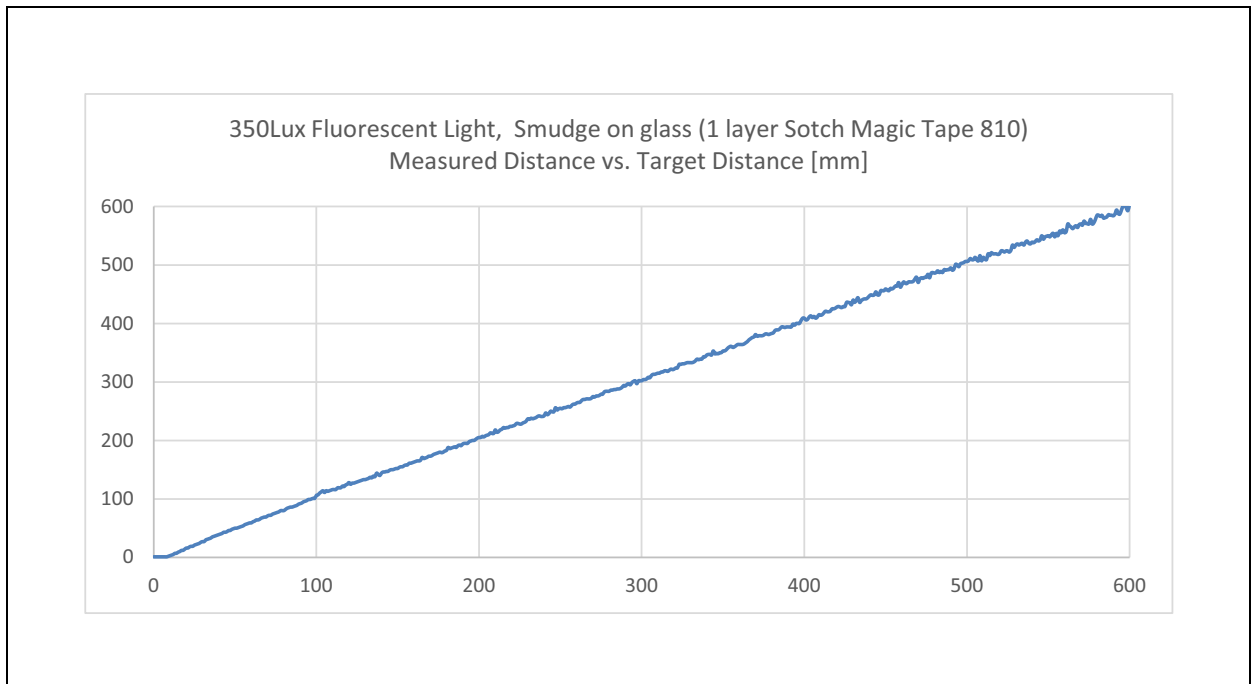

Figure 9:
14kLux Halogen Light (100kLux Sunlight Equivalent)

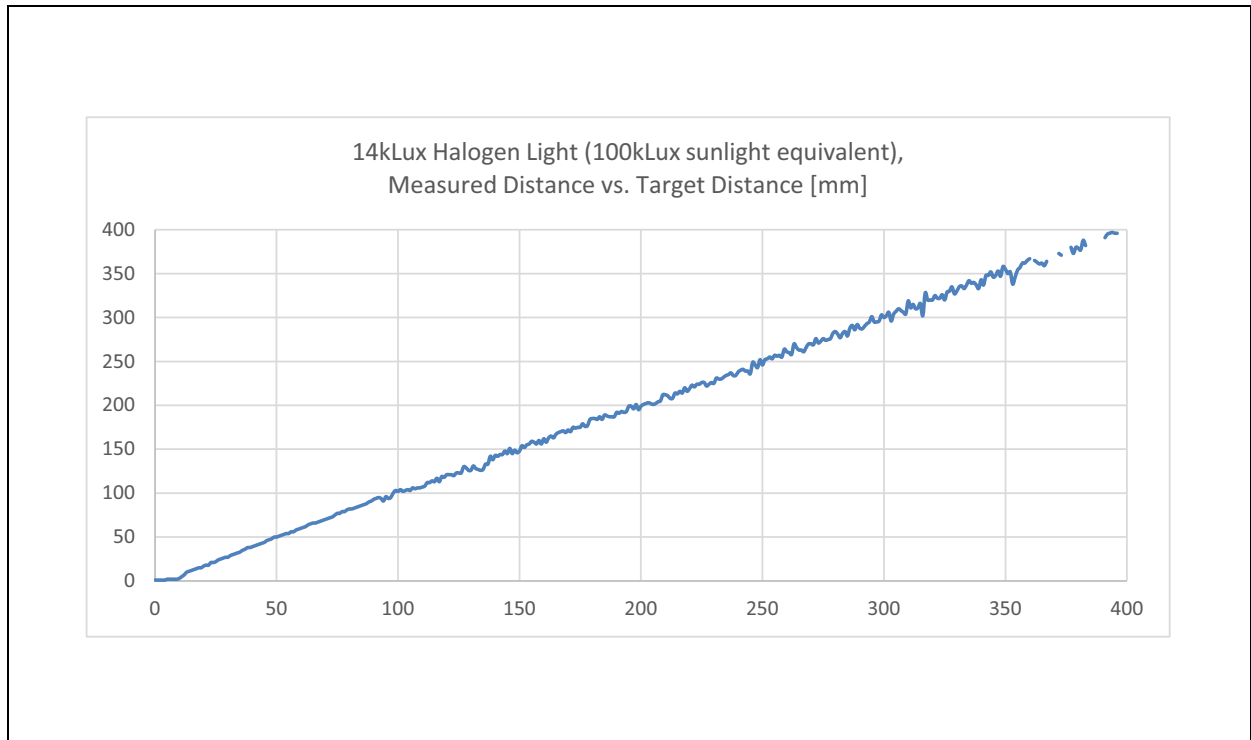
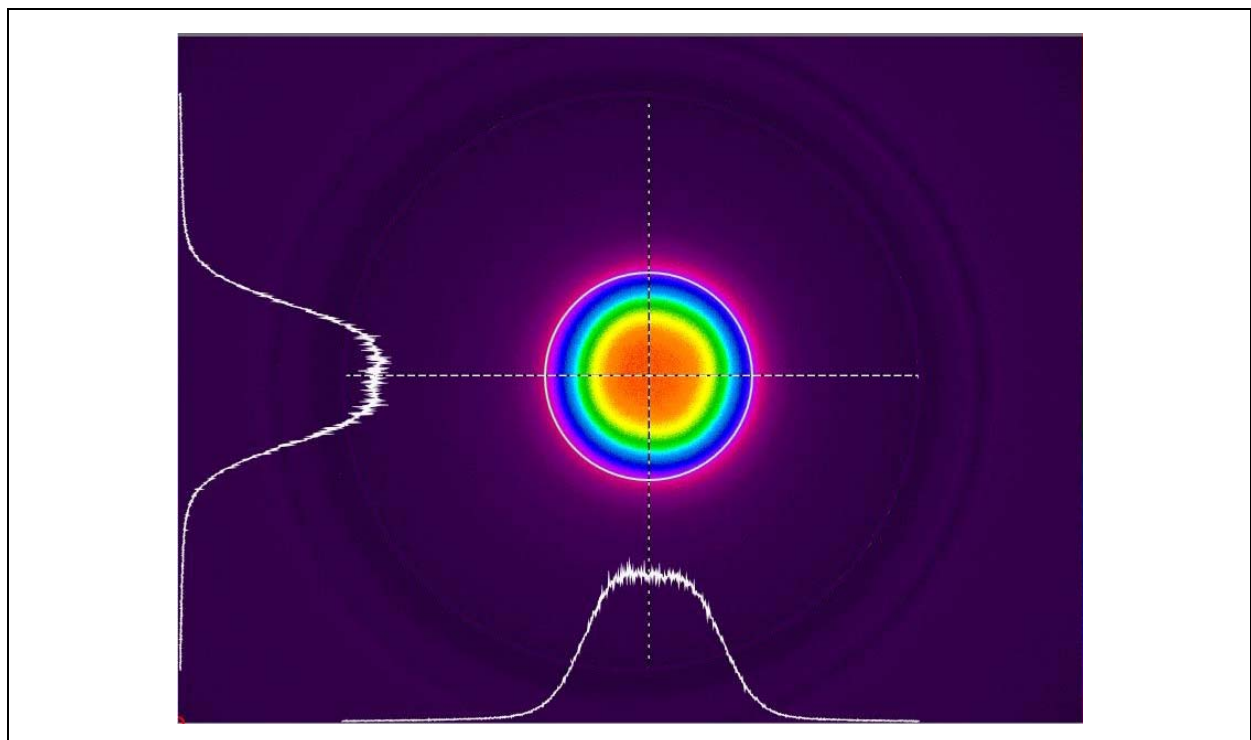

Figure 10:
Field of Illumination of VCSEL (FOI), x-axis: $\pm 10.4^\circ$, y-axis: $\pm 10.31^\circ$, $1/e^2$



Detailed Description

I²C Protocol

The TMF8701 is controlled by an I²C bus, one interrupt pin and two GPIO pins.

The device uses I²C serial communication protocol for communication. The device supports 7-bit chip addressing and standard, fast mode and fast mode plus modes. Read and Write transactions comply with the standard set by Philips (now NXP). For a complete description of the I²C protocol, please review the NXP I²C design specification.

Internal to the device, an 8-bit buffer stores the register address location of the byte to read or write. This buffer auto-increments upon each byte transfer and is retained between transaction events (i.e. valid even after the master issues a STOP and the I²C bus is released). During consecutive Read transactions, the future/repeated I²C Read transaction may omit the memory address byte normally following the chip address byte; the buffer retains the last register address +1.

A Write transaction consists of a START, CHIP-ADDRESSWRITE, REGISTER-ADDRESSWRITE, DATA BYTE(S), and STOP. Following each byte (9th clock pulse) the slave places an ACKNOWLEDGE/NOT-ACKNOWLEDGE (ACK/NACK) on the bus. If NACK is transmitted by the slave, the master may issue a STOP.

A Read transaction consists of a START, CHIP-ADDRESSWRITE, REGISTER-ADDRESS, RESTART, CHIP-ADDRESSREAD, DATA BYTE(S), and STOP. Following all but the final byte the master places an ACK on the bus (9TH clock pulse). Termination of the Read transaction is indicated by a NACK being placed on the bus by the master, followed by STOP.

TOF Description

System Parameters

The on-chip microprocessor is a Cortex M0 μ P.

Figure 11:
ARM M0 Parameters

	Min	Typ	Max	Units	Comment
μ P Operating Frequency		5.37	86	MHz	The CPU can operate with the rc oscillator directly or with a 16x PLL
RAM			32	kB	
ROM			32	kB	
Max PLL Frequency		172		MHz	

Standard I²C Timing for 1MHz Fast Mode Plus with lower drive. The default TOF address is 0x41.

The address can be changed after power-up. Use the enable pin to enable only one device at a time to provide a unique device addresses.

I/O

Figure 12:
Typical I/O Level Specification

Symbol	Parameter	Condition	Min	Typ	Max	Units
ILEAK	SDA, SCL, GPIO0/1, EN, INT		-5		5	μ A
VIH ⁽¹⁾	SDA, SCL, GPIO0/1, EN		1.26			V
VIL_I2C ⁽¹⁾	SDA, SCL	2.7V < VDD < 2.9V, < 400kHz I ² C speed			0.3	V
		VDD > 2.9V, < 400kHz I ² C speed			0.54	
		2.8V < VDD < 3.0V, < 1MHz I ² C speed			0.3	
		VDD > 3.0V, < 1MHz I ² C speed			0.54	
VIL	GPIO0/1, EN				0.54	V
VOL	SDA, GPIO0/1, INT	2mA sink	0		0.36	V
		4mA sink	0		0.6	V
IDRIVE_H	GPIO0/1	1V applied on GPIO	3.6			mA
IDRIVE_L	GPIO0/1	1V applied on GPIO	3.9			mA

Note(s):

1. The input high level VIH and low level VIL is defined to support a pull-up supply of 1.8V \pm 5%.

Power Consumption

All current consumption values include silicon process variation. Temperature and voltages are at nominal conditions (23°C and 2.8V).

Figure 13:
Power Consumption

	Condition	Min	Typ	Max	Units	Comment
I_VDD Power down	Enable Pin Low I ² C Off	0.02	0.26	1	μA	State: Power down
I_VDD Standby CPU Off, RAM On OSC Off, pon=0 I ² C Wakeup Only			85		μA	State: Standby
I_VDD Wait CPU Off, RAM On, OSC On 5MHz I ² C On, Timer Wakeup			140		μA	State: Wait
I_VDD Ranging Processing CPU Running at 80MHz No VCSEL, No TDC			2.7		mA	State: Histogram processing
I_VDD Ranging Active CPU stopped VCSEL 43MHz 320ps pulses, TDCs running			32.5		mA	State: Ranging active
I_VDD Background measurement Active CPU stopped VCSEL off, TDCs running			13		mA	
I_VDD Ranging 60Hz, 16.6ms, distance and proximity algorithm combined			26		mA	Average power consumption
Peak VCSEL Current 320ps pulses			230		mA	
Max VCSEL Duty Cycle			2		%	

Timing

Ranging Acquisition Timing

Figure 14:
Ranging Acquisition Timing

	Min	Typ	Max	Units	Comment
Ranging time proximity and distance mode combined		16.6		ms	Varies with operational mode
Ranging init (including electrical calibration)		8		ms	Only done on startup and if temperature changed from last calibration
Ranging period			209	ms	Programmable by the interface

Figure 15:
Ranging Timing Diagram

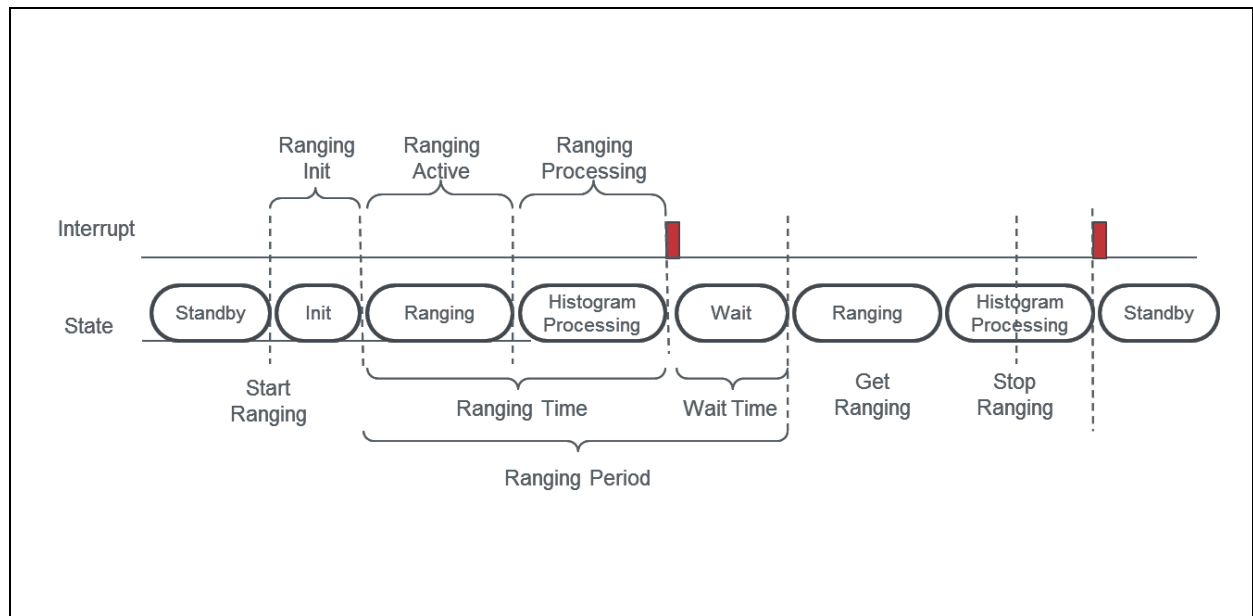

Reset Pin and Power-Up Timing

Figure 16:
Reset Pin and Power-Up Timing

	Min	Typ	Max	Units	Comment
Power On (boot time)		3		ms	Does not include RAM download time
Enable High to Ready for Measurement		8		ms	
Standby to Active Time		<<1		ms	
Active to Standby Time		<<1		ms	
Enable Low to Power Down Time		<<1		ms	

Distance and Proximity Algorithm

As the performance of the algorithm is dependent on the ROM version, following section only applies for devices with order code TMF8701-1B (and TMF8701-1BM), calibrated and in-application oscillator calibration using the reference driver code and patched with the latest software patch from **ams** (contact **ams** to identify latest patch version).

The TMF8701 is embedded in the application using a 0.38mm airgap and a glass with an IR ink with >90% transmissivity. The glass thickness is 0.5mm. An additional mask on the opaque ink is implemented according to TMF8701 optical design guide (external document).

Calibration

To achieve the performance described in the next sections, a calibration of the algorithm needs to be performed (command = 0x0A). The TMF8701 shall be embedded in the final application and the cover glass including the IR ink needs to be assembled. The calibration test shall be done in a housing with minimal ambient light and no target within 40cm in FOI of the TMF8701.

The TMF8701 generates a calibration data set which is permanently stored on the host.

On each power-up of the TMF8701 the calibration data set is sent by I²C to the TMF8701 prior to execution of any algorithms (commands=0x02 or 0x0B).

Operating Modes and Timings

The TMF8701 can be operated in two different modes:

- Proximity mode only; it uses 80k iterations at 43Mhz for capturing (VCSEL on).
- Proximity and distance mode combined; it uses 80k + 320k iterations at 43Mhz for capturing.

The operating modes have different timings as shown in following table:

**Figure 17:
Algorithm Timings**

	Condition	Min	Nom	Max	Units
Proximity Mode only	command=0x02 or 0x03 cmd_data6=0x81		5.3		ms
Proximity and Distance Mode Combined	command=0x02 or 0x03 cmd_data6=0xA3		16.6		ms

Proximity Mode

The proximity algorithm reports a distance information in steps of 1mm and the detect/release threshold can be tuned inside the host. It especially can detect objects close to touch. For proper operation of the proximity mode a cover glass with IR ink is assumed.

**Figure 18:
Proximity Mode Parameters**

	Condition	Min	Nom	Max	Units
Reflectivity of Object at 940nm	Full FOV target assumed	5		90	%
Ambient Light	Halogen light ⁽¹⁾	0		14k ⁽²⁾	lux
Object Detected		1.0 ⁽³⁾		20 ⁽⁴⁾	mm
Object Released		60 ⁽⁴⁾			mm
Difference Object Detected / Object Released	Appropriate but fixed thresholds for detect / release in the host assumed	10			mm

Note(s):

1. On the DUT or on the target; for close distances the target will shield ambient light.
2. 14k halogen light represents 100k sunlight equivalent
3. To detect a target at close distances, the algorithm relies on historical information. Therefore a grey or white target had to be present previously at approximately 60mm for obtaining this information.
4. These exact numbers apply for a 18% reflectivity target; due to the short distance a full FOV object perpendicular to TMF8701 is assumed.

Proximity and Distance Mode Combined

In the combined operating mode, proximity algorithm is run first followed by distance algorithm. An object detected in proximity mode has priority over an object detected in distance mode.

The distance algorithm reports a distance information of the closest object in 1mm steps.

**Figure 19:
Distance Mode Parameters**

	Condition	Min	Nom	Max	Units
Reflectivity of Object at 940nm	20cmx26cm target, perpendicular to TMF8701	18		90	%
Maximum Distance Detection, 18% Grey Card, 20cmx26cm	<350 lux fluorescent on object		600		mm
	14k lux halogen light on object ⁽¹⁾		350		mm
Minimum Distance Detection, 18% Grey Card, 20cmx26cm ⁽²⁾			60	100	mm
Accuracy	Object distance ≥ 200mm		±5		%
	100mm < object distance < 200mm		±10		mm

Note(s):

1. 14k lux halogen light represents 100k lux sunlight equivalent; light on object only.
2. If proximity mode detects an object within ≤ 100mm, it is reported. Only if proximity mode does not detect an object, distance mode result is used. Therefore the full range starting from minimum proximity distance (1mm) to maximum distance for distance mode (600mm) is covered.

VCSEL

Internal protection ensures no single point of failure will cause the VCSEL to violate the Class 1 Laser Safety.

Laser Safety: Class 1

VCSEL Pulse Rep. Rate: 23ns (43MHz)

Typical Optical Characteristics

VCSEL Field of Illumination (FOI): 21° Full width from 5% of maximum up to maximum
 : 19° 1/e²

TOF Sensor Field of View (FOV): 37° FWHM – in proximity mode
 : 24° FWHM – in distance mode

This Rx SPAD FoV angular response simulates the TMF8701 operation in proximity mode based on the entire SPAD array. The Rx SPAD FoV angular response is reduced when the TMF8701 operates in distance mode since the SPAD array is reduced. This helps to improve ambient light tolerance.

Figure 20:
FOI/FOV of TMF8701

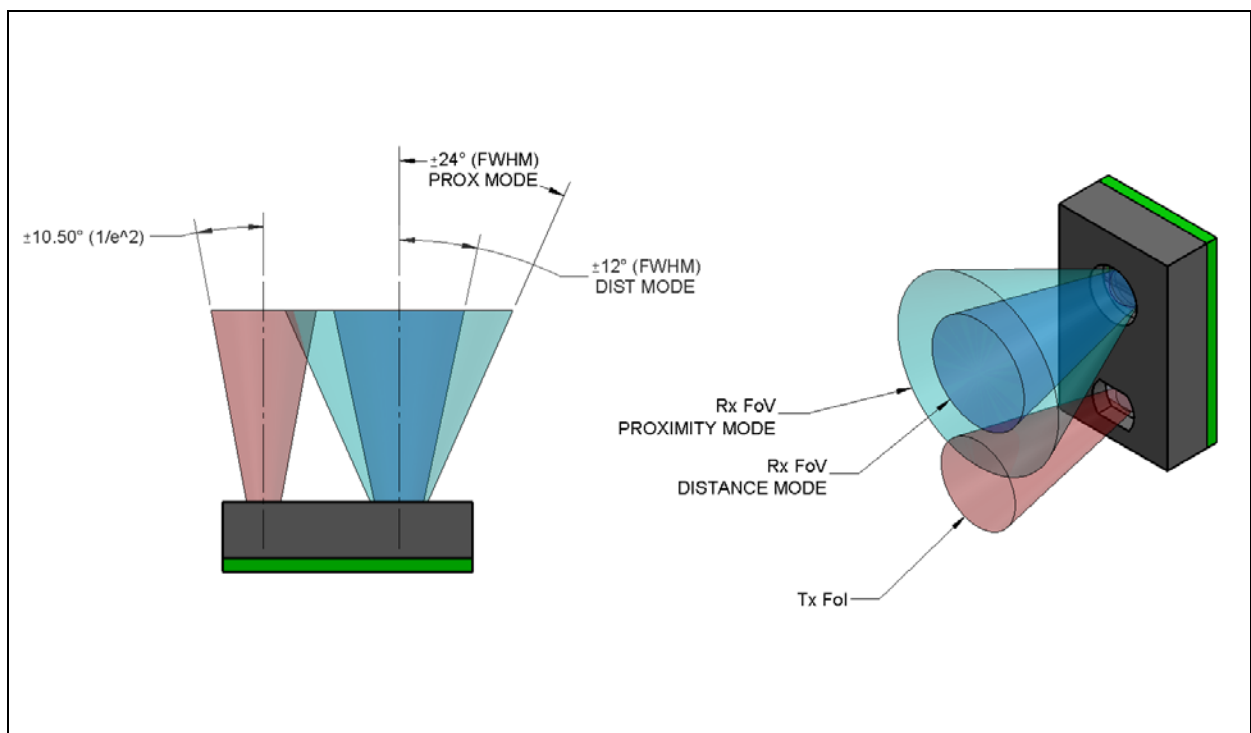

Filter Characteristics

FWHM: 56nm
 Passband Center Frequency: 940nm
 Min. Stopband Frequency: 350nm
 Max. Stopband Frequency: 1100nm

Register Description

Register Overview

Figure 21:
APPID Register

0x00: APPID				
Field	Name	Reset	Type	Description
7:0	appid	0	RW	Currently running application: 0xC0.... App0 - Measurement application running 0x80.... Bootloader running

Figure 22:
APPREV MAJOR Register

0x01: APPREV MAJOR				
Field	Name	Reset	Type	Description
7:0	apprevMajor	0	RW	Application major revision

Figure 23:
APPREQID Register

0x02: APPREQID				
Field	Name	Reset	Type	Description
7:0	appReqid	0	RW	Application that shall be started, set this to 0x80.... Bootloader 0xC0.... App0 – Measurement application and wait until register 0x00 (APPID) shows this as application.

Note(s):

- Further application IDs might be added in the future.

Figure 24:
ENABLE Register

0xe0: ENABLE				
Field	Name	Reset	Type	Description
7	cpu_reset	0	RW_SC	Write a '1' here to reset CPU. This generates global reset, fully resetting CPU and all CPU registers. The bit resets itself, no need to explicitly clear it.
6	cpu_ready	0	RO	CPU is ready to handle I ² C - if this bit is zero, then only the registers 0xe0 and above are usable, the memory mapped I ² C space is not used. Bit gets set only explicitly by software, therefore a functional and running firmware is necessary for this bit to work.
0	pon	1	R_PUSH	1 = Activate oscillator 0 = Ask cpu to go to standby Activating the oscillator is implemented in hardware. Whenever this register is '0' and a '1' is being written, the oscillator is being started and CPU receives a PON1 interrupt. It is implemented in the bootloader to execute a reset at this point, but the application goes to an IDLE state. De-activating the oscillator is a software assisted process. It is important that the CPU powers down all modules properly before turning off the oscillator, therefore this is implemented in firmware. So writing a '0' to this register will trigger an internal CPU interrupt. The firmware, after powering down everything, sets the device into standby state.

Figure 25:
INT_STATUS Register

0xe1: INT_STATUS				
Field	Name	Reset	Type	Description
1	int2	0	R_PUSH1	Raw histogram available interrupt for App0; asserted when a raw histogram can be retrieved from I ² C. int2 status. If bis is asserted, and int2_enab is asserted as well, then the INT pin will be pulled low. Writing a '1' here will clear int1 condition.
0	int1	0	R_PUSH1	Object detection interrupt for App0; asserted when a result from object detection is available int1 status. If bis is asserted, and int1_enab is asserted as well, then the INT pin will be pulled low. Writing a '1' here will clear int1 condition.

Figure 26:
INT_ENAB Register

0xe2: INT_ENAB				
Field	Name	Reset	Type	Description
1	int2_enab	0	RW	Raw histogram available interrupt for App0; asserted when a raw histogram can be retrieved from I ² C. 0 = Disabled, 1 = Enabled -> INT output is active if int2 flag is "1"
0	int1_enab	0	RW	Object detection interrupt for App0; asserted when a result from object detection is available 0 = Disabled, 1 = Enabled -> INT output is active if int1 flag is "1"

Figure 27:
ID Register

0xe3: ID				
Field	Name	Reset	Type	Description
5:0	id	0	RO	Chip ID, reads 07h – Do not rely on register bits 6 and 7 of this register.

Figure 28:
REVID Register

0xe4: REVID				
Field	Name	Reset	Type	Description
2:0	rev_id	0	RO	Chip revision ID

App0 Registers – appid=0xC0

Following registers are only available if appid=0xC0 (App0):

Figure 29:
CMD_DATA9 Register

0x06: CMD_DATA9				
Field	Name	Reset	Type	Description
7:0	cmd_data9	0	W	Command data 9 – see register command for future extension of commands

Figure 30:
CMD_DATA8 Register

0x07: CMD_DATA8				
Field	Name	Reset	Type	Description
7:0	cmd_data8	0	W	Command data 8 – see register command for future extension of commands

Figure 31:
CMD_DATA7 Register

0x08: CMD_DATA7				
Field	Name	Reset	Type	Description
7:0	cmd_data7	0	W	Command data 7 – see register command

Figure 32:
CMD_DATA6 Register

0x09: CMD_DATA6				
Field	Name	Reset	Type	Description
7:0	cmd_data6	0	W	Command data 6 – see register command

Figure 33:
CMD_DATA5 Register

0x0a: CMD_DATA5				
Field	Name	Reset	Type	Description
7:0	cmd_data5	0	W	Command data 5 – see register command

Figure 34:
CMD_DATA4 Register

0x0b: CMD_DATA4				
Field	Name	Reset	Type	Description
7:0	cmd_data4	0	W	Command data 4– see register command

Figure 35:
CMD_DATA3 Register

0x0c: CMD_DATA3				
Field	Name	Reset	Type	Description
7:0	cmd_data3	0	W	Command data 3 – see register command

Figure 36:
CMD_DATA2 Register

0x0d: CMD_DATA2				
Field	Name	Reset	Type	Description
7:0	cmd_data2	0	W	Command data 2 – see register command

Figure 37:
CMD_DATA1 Register

0x0e: CMD_DATA1				
Field	Name	Reset	Type	Description
7:0	cmd_data1	0	W	Command data 1 – see register command

Figure 38:
CMD_DATA0 Register

0x0f: CMD_DATA0				
Field	Name	Reset	Type	Description
7:0	cmd_data0	0	W	Command data 0 – see register command

Figure 39:
COMMAND Register

0x10: COMMAND										
Field	Name	Reset	Type	Description						
7:0	Command	0	RW	Direct the device to control or select contents of the registers from 0x20...0xDF						
				<table border="1"> <thead> <tr> <th>Setting</th> <th>Meaning</th> </tr> </thead> <tbody> <tr> <td>0x00</td> <td>No command</td> </tr> <tr> <td>0x02</td> <td> Set flag to perform distance or proximity measurement with 8 bytes of data containing where including setting of calibration (and algorithm state) configuration. cmd_data7 = Bit mask which calibration/state data was downloaded from the host to TMF8701 prior to setting this command: Bit 0 - dataFactoryCal: when 1 data from register 0x20 onward includes factory calibration Bit 1 - dataAlgState: if set, also set dataFactoryCal=1. Data from register 0x20 onwards includes factory calibration and algorithm state. cmd_data6... cmd_data0 : Identical to command=0x03. </td> </tr> </tbody> </table>	Setting	Meaning	0x00	No command	0x02	Set flag to perform distance or proximity measurement with 8 bytes of data containing where including setting of calibration (and algorithm state) configuration. cmd_data7 = Bit mask which calibration/state data was downloaded from the host to TMF8701 prior to setting this command: Bit 0 - dataFactoryCal: when 1 data from register 0x20 onward includes factory calibration Bit 1 - dataAlgState: if set, also set dataFactoryCal=1. Data from register 0x20 onwards includes factory calibration and algorithm state. cmd_data6... cmd_data0 : Identical to command=0x03.
Setting	Meaning									
0x00	No command									
0x02	Set flag to perform distance or proximity measurement with 8 bytes of data containing where including setting of calibration (and algorithm state) configuration. cmd_data7 = Bit mask which calibration/state data was downloaded from the host to TMF8701 prior to setting this command: Bit 0 - dataFactoryCal: when 1 data from register 0x20 onward includes factory calibration Bit 1 - dataAlgState: if set, also set dataFactoryCal=1. Data from register 0x20 onwards includes factory calibration and algorithm state. cmd_data6... cmd_data0 : Identical to command=0x03.									

0x10: COMMAND				
Field	Name	Reset	Type	Description
			0x03	<p>Set flag to perform distance or proximity measurement with 7 bytes of data containing where</p> <p>cmd_data6 = Bit mask which algorithm is used Bit 0 - When 1 proximity is enabled Bit 1 - When 1 distance enabled Bits 3:2 - Reserved; set to 00b. Bits 4 - algImmediateInterrupt – When 1 proximity and distance will immediately report to the host an interrupt of the capturing caused by a GPIO event; when 0, will only report to the host when proximity (and distance if enabled) was finished Bit 5 - When 1 combine the capture of the proximity and distance algorithms for maximum speed Bit 6 - Reserved; set to 0. Bit 7 - When 1 do not go to standby between measurements (faster measurement times but higher current consumption) Please note if bits 0 and 1 are both zero, the system will default to proximity and distance algorithms enabled.</p> <p>cmd_data5 = Bits for GPIO control Bits 3:0 - GPIO0 settings 0 – Disabled (tristate) 1 - Input: Active low disables collection, immediately abandoning current measurement. Returning to high restarts new measurement 2 - Input: Active high disables collection, immediately abandoning current measurement. Returning to low restarts new measurement 3 - Output: VCSEL pulse output - see cmd_data4 4 - Output low (default after startup) 5 - Output high 6:15 – Reserved, do not use Bits 7:4 - GPIO1 settings 0 - Disabled (tristate) 1 - Input: Active low disables collection, immediately abandoning current measurement. Returning to high restarts new measurement 2 - Input: Active high disables collection, immediately abandoning current measurement. Returning to low restarts new measurement 3 - Output: VCSEL pulse output – see cmd_data4 4 - Output low (default after startup) 5 - Output high 6:15 – Reserved, do not use</p>

0x10: COMMAND				
Field	Name	Reset	Type	Description
				<p>cmd_data4 = If cmd_data5 enables VCSEL pulse output for GPIO0 and/or GPIO1, cmd_data4 sets its timings as follows. If set to non-zero, GPIO1 shows the VCSEL pulse; additionally the GPIO1 signal can be set to be asserted before the VCSEL pulse starts</p> <p>'0' - No signal, '1' - GPIOx, rises 0µs time before VCSEL pulse starts '2' - GPIOx rises 100µs before VCSEL pulse, '3' - GPIOx rises 200µs before VCSEL pulse and so on. The falling edge of GPIOx happens at the same time the VCSEL stops emitting light.</p> <p>cmd_data3 = Reserved for future, use 0x00.</p> <p>cmd_data2 = Repetition period in ms, use 0 for single measurement; if the repetition period is set lower than the ranging time for this mode, the TMF8701 runs at its maximum possible speed (best effort approach).</p> <p>cmd_data1 = Reserved for future, use 0xFF</p> <p>cmd_data0 = Reserved for future, use 0xFF</p> <p>Once a measurement is finished the interrupt is asserted if it is enabled by int1_enab. Additionally the transaction ID tid is updated.</p>
			0x04	<p>Set flag to perform distance measurement (no proximity algorithm is used) with 5 bytes of data containing where:</p> <p>cmd_data4 = If set to non-zero, GPIO1 shows the VCSEL pulse; additionally the GPIO1 signal can be set to be asserted before the VCSEL pulse starts,</p> <p>0 for no signal, '1'=0µs time before VCSEL pulse '2'=GPIO1 starts 100µs before VCSEL pulse, '3'= GPIO1 starts 200µs before VCSEL pulse.</p> <p>cmd_data3 = Reserved for future, use 0x00</p> <p>cmd_data2 = Repetition period in ms, use 0 for single ranging; if the repetition period is set lower than the ranging time for this mode, the TMF8701 runs at its maximum possible speed (best effort approach)</p> <p>cmd_data1 = Reserved for future, use 0xFF</p> <p>cmd_data0 = Reserved for future, use 0xFF</p> <p>Once a measurement is finished the interrupt is asserted if it is enabled by int1_enab. Additionally the transaction ID tid is updated.</p>

0x10: COMMAND				
Field	Name	Reset	Type	Description
				0x0A Perform factory calibration in the final customer application including cover glass, no ambient light and no target. The result from the factory calibration is stored from register 0x20 onwards (14 bytes).
				0x0B Set flag to download calibration (and algorithm state) configuration to TMF8701. cmd_data0 = bit mask which calibration/state data was downloaded from the host to TMF8701 prior to setting this command: Bit 0 - dataFactoryCal: When 1 data from register 0x20 onward includes factory calibration Bit 1 - dataAlgState: If set, also set dataFactoryCal=1. Data from register 0x20 onwards includes factory calibration and algorithm state.
				0x0F Set gpio control setting without actually performing a measurement as commands 0x02 or 0x03 would do: cmd_data0 = bits for GPIO control Bits 3:0 - GPIO0 settings 0 - Disabled 1 - Input: Active low disables collection, immediately abandoning current measurement. Returning to high restarts new measurement 2 - Input: Active high disables collection, immediately abandoning current measurement. Returning to low restarts new measurement 3 - Output: VCSEL pulse output 4 - Output low 5 - Output high 6:15 - Reserved, do not use Bits 7:4 - GPIO1 settings 0 - Disabled 1 - Input: Active low disables collection, immediately abandoning current measurement. Returning to high restarts new measurement 2 - Input: Active high disables collection, immediately abandoning current measurement. Returning to low restarts new measurement 3 - Output: VCSEL pulse output 4 - Output low 5 - Output high 6:15 - Reserved, do not use

0x10: COMMAND				
Field	Name	Reset	Type	Description
				<p>Enable histogram readout; the internal state machine will stop when a histogram (e.g. calibration) is available and wait for readout by the host. If the selected histogram is readout, the host shall continue the state machine by sending command 0x32</p> <p>cmd_data3 = Bitmask for the histograms to be readout:</p> <ul style="list-style-type: none"> • Always set bit 0 to '0' • Set bit 1 to get electrical calibration histograms • Set bit 2 to get optical calibration histogram • Always set bit 3 to '0' • Set bit 4 to get proximity histograms • Always set bit 5 and 6 to '0' • Set bit 7 to get distance measurement histograms <p>cmd_data2 = Set to 0x00</p> <p>cmd_data1 = bitmask for pileup correct histograms readout:</p> <ul style="list-style-type: none"> • Set bit 0 to get pileup corrected distance measurement histograms • Set bit 1 to get pileup corrected sum histogram • Set bit 2 to get pileup corrected proximity histogram • Always set bit 3-7 to 0 <p>cmd_data0 = Set to 0x00</p> <p>Once above bitmask is set, the device is programmed to stop when the histogram is available. Set command=0x04 to actually perform the measurement.</p>
			0x30	
			0x32	After the host has readout the histogram, continue with internal processing.
			0x47	Read out serial number – results see section Serial Number Readout – If Register register_contents=0x47
			0x80 ... 0x93	Read 1 quarter of one histogram - copy histogram bits[4:2] to select TDC0... TDC5, quarter bits[1:0] into 0x20... 0x9f ^{(1), (2)}
			0xff	Stop whatever you are doing as soon as possible and reenter the idle state. The current state will not be interrupted and will require leaving the current state processing to take effect. This command will stop continuous measurement.

Note(s):

1. At the end of the transaction of read a quarter, the contents of the registers from 0x20-0x9F will be automatically updated, and the contents of registers REGISTER_CONTENTS and TID will be updated.
2. At the end of a TDC, the TDC number will also auto increment.

Figure 40:
PREVIOUS Register

0x11: PREVIOUS				
Field	Name	Reset	Type	Description
7:0	previousCommand	0	RO	Previous command that was executed (or current if continues mode is selected)

Figure 41:
APPREV_MINOR Register

0x12: APPREV_MINOR				
Field	Name	Reset	Type	Description
7:0	appRevMinor	0	RO	Application minor revision

Figure 42:
APPREV_PATCH Register

0x13: APPREV_PATCH				
Field	Name	Reset	Type	Description
7:0	appRevPatch	0	RO	Application patch number

Figure 43:
STATUS Register

0x1d:STATUS					
Field	Name	Reset	Type	Description	
7:0	Status	0	RO	Current status or current general operation	
				Setting	Meaning
				0x00-0x0F	Ok
				0x10-0xFF	Error

Figure 44:
REGISTER_CONTENTS Register

0x1e: REGISTER_CONTENTS				
Field	Name	Reset	Type	Description
7:0	register_contents	0	RO	Current contents of the I ² C ram from 0x20 to 0xEF; the coding is as follows: 0Ah ... Calibration data 47h ... Serial Number 55h ... Results for commands 0x02/0x03 and 0x04 80h-93h ... Raw histogram data where 80h=TDC0, bin 0... 63 81h=TDC0, bin 64... 127 82h=TDC0, bin 128... 195 83h=TDC0, bin 196... 255 84h=TDC1, bin 0... 63 ... 93h=TDC4, bin 196... 255

Figure 45:
TID Register

0x1f: TID				
Field	Name	Reset	Type	Description
7:0	tid	0	RO	Unique transaction ID, changes with every update of register map by TOF

Object Detection Results – If Register register_contents =0x55 (Commands 0x02,0x03 or 0x04)

Figure 46:
RESULT_NUMBER Register

0x20: RESULT_NUMBER				
Field	Name	Reset	Type	Description
7:0	result_num	0	RO	Result number, incremented every time there is a unique answer

Figure 47:
RESULT_INFO Register

0x21: RESULT_INFO					
Field	Name	Reset	Type	Description	
5:0	reliability	0	RO	Reliability of object - valid range 0 to 63 where 63 is best	
7:6	measStatus	0	RO	When algImmediateInterrupt == 1	
				Will indicate the status of the measurement.	
				Value	Definition
				0	Proximity capture interrupted, using previous proximity only result
				1	Proximity capture interrupted, using previous proximity and distance result
				2	Distance capture interrupted, result is from proximity algorithm only
				3	Complete result (distance and proximity)
				When algImmediateInterrupt == 0	
				Will indicate the status of the measurement.	
				Value	Definition
				0	Measurement was not interrupted
				1	Reserved
				2	Measurement was interrupted (delay) by GPIO interrupt
				3	Reserved

Figure 48:
DISTANCE_PEAK_0 Register

0x22: DISTANCE_PEAK_0				
Field	Name	Reset	Type	Description
7:0	distance_peak[7:0]	0	RO	Distance to the peak in [mm] of the object, least significant byte

Figure 49:
DISTANCE_PEAK_1 Register

0x23: DISTANCE_PEAK_1				
Field	Name	Reset	Type	Description
7:0	distance_peak[15:8]	0	RO	Distance to the peak in [mm] of the object, most significant byte

The sys clock registers is a running timer information – this value is counting up (and wraps around to 0 again) as long as the internal clock is running. As it is derived from the internal RC oscillator and distance information is depending on its accuracy, it can be used to correct an algorithm result by comparing this clock with a more accurate clock inside the host. For correctly updating of these registers by TMF8701, an I²C blockread starting from address 0x1D until 0x27 shall be done.

Figure 50:
SYS_CLOCK_0 Register

0x24: SYS_CLOCK_0				
Field	Name	Reset	Type	Description
7:0	sys_clock[7:0]	0	RO	System clock/time stamp in units of 0.2μs

Figure 51:
SYS_CLOCK_1 Register

0x25: SYS_CLOCK_1				
Field	Name	Reset	Type	Description
7:0	sys_clock[15:8]	0	RO	System clock/time stamp in units of 0.2μs

Figure 52:
SYS_CLOCK_2 Register

0x26: SYS_CLOCK_2				
Field	Name	Reset	Type	Description
7:0	sys_clock[23:16]	0	RO	System clock/time stamp in units of 0.2μs

Figure 53:
SYS_CLOCK_3 Register

0x27: SYS_CLOCK_3				
Field	Name	Reset	Type	Description
7:0	sys_clock[31:24]	0	RO	System clock/time stamp in units of 0.2 μ s

Algorithm state information is captured in the next registers. To allow resume of operation after power-off, algorithm state can be stored temporarily inside the host and once after power-on of TMF8701 restored to resume operation.

Figure 54:
STATE_DATA_0 Register

0x28: STATE_DATA_0				
Field	Name	Reset	Type	Description
7:0	state_data_0	0	RO	Algorithm state data

Figure 55:
STATE_DATA_1 Register

0x29: STATE_DATA_1				
Field	Name	Reset	Type	Description
7:0	state_data_1	0	RO	Algorithm state data

Figure 56:
STATE_DATA_2 Register

0x2a: STATE_DATA_2				
Field	Name	Reset	Type	Description
7:0	state_data_2	0	RO	Algorithm state data

Figure 57:
STATE_DATA_3 Register

0x2b: STATE_DATA_3				
Field	Name	Reset	Type	Description
7:0	state_data_3	0	RO	Algorithm state data

Figure 58:
STATE_DATA_4 Register

0x2c: STATE_DATA_4				
Field	Name	Reset	Type	Description
7:0	state_data_4	0	RO	Algorithm state data

Figure 59:
STATE_DATA_5 Register

0x2d: STATE_DATA_5				
Field	Name	Reset	Type	Description
7:0	state_data_5	0	RO	Algorithm state data

Figure 60:
STATE_DATA_6 Register

0x2e: STATE_DATA_6				
Field	Name	Reset	Type	Description
7:0	state_data_6	0	RO	Algorithm state data

Figure 61:
STATE_DATA_7 Register

0x2f: STATE_DATA_7				
Field	Name	Reset	Type	Description
7:0	state_data_7	0	RO	Algorithm state data

Figure 62:
STATE_DATA_8 Register

0x30: STATE_DATA_8				
Field	Name	Reset	Type	Description
7:0	state_data_8	0	RO	Algorithm state data

Figure 63:
STATE_DATA_9 Register

0x31: STATE_DATA_9				
Field	Name	Reset	Type	Description
7:0	state_data_9	0	RO	Algorithm state data

Figure 64:
STATE_DATA_10 Register

0x32: STATE_DATA_10				
Field	Name	Reset	Type	Description
7:0	state_data_10	0	RO	Algorithm state data

Reference hits and object hits are used for information purposes of the target object and are only reported if a target is detected with the distance algorithm.

Figure 65:
REFERENCE_HITS_0 Register

0x33: REFERENCE_HITS_0				
Field	Name	Reset	Type	Description
7:0	reference_hits[7:0]	0	RO	Sum of the reference SPADs hits during the distance measurement; zero if no object is detected or distance algorithm is no used

Figure 66:
REFERENCE_HITS_1 Register

0x34: REFERENCE_HITS_1				
Field	Name	Reset	Type	Description
7:0	reference_hits[15:8]	0	RO	Sum of the reference SPADs hits during the distance measurement; zero if no object is detected or distance algorithm is no used

Figure 67:
REFERENCE_HITS_2 Register

0x35: REFERENCE_HITS_2				
Field	Name	Reset	Type	Description
7:0	reference_hits[23:16]	0	RO	Sum of the reference SPADs hits during the distance measurement; zero if no object is detected or distance algorithm is no used

Figure 68:
REFERENCE_HITS_3 Register

0x36: REFERENCE_HITS_3				
Field	Name	Reset	Type	Description
7:0	reference_hits[31:24]	0	RO	Sum of the reference SPADs hits during the distance measurement; zero if no object is detected or distance algorithm is no used

Figure 69:
OBJECT_HITS_0 Register

0x37: OBJECT_HITS_0				
Field	Name	Reset	Type	Description
7:0	object_hits[7:0]	0	RO	Sum of the reference SPADs hits during the distance measurement; zero if no object is detected or distance algorithm is no used

Figure 70:
OBJECT_HITS_1 Register

0x38: OBJECT_HITS_1				
Field	Name	Reset	Type	Description
7:0	object_hits[15:8]	0	RO	Sum of the reference SPADs hits during the distance measurement; zero if no object is detected or distance algorithm is no used

Figure 71:
OBJECT_HITS_2 Register

0x39: OBJECT_HITS_2				
Field	Name	Reset	Type	Description
7:0	object_hits[23:16]	0	RO	Sum of the reference SPADs hits during the distance measurement; zero if no object is detected or distance algorithm is no used

Figure 72:
OBJECT_HITS_3 Register

0x3a: OBJECT_HITS_3				
Field	Name	Reset	Type	Description
7:0	object_hits[31:24]	0	RO	Sum of the reference SPADs hits during the distance measurement; zero if no object is detected or distance algorithm is no used

Calibration and Algorithm State Data Exchange

These registers shall be pre-loaded by the host before command=0x02 or 0x0B is executed

Figure 73:
FACTORY_CALIB_0 Register

0x20: FACTORY_CALIB_0				
Field	Name	Reset	Type	Description
7:0	factory_calib_0	0	RW	Factory calibration data bits[3:0] are format revision bits[7:4] are bits [3:0] of crosstalk measurement

Figure 74:
FACTORY_CALIB_1 Register

0x21: FACTORY_CALIB_1				
Field	Name	Reset	Type	Description
7:0	factory_calib_1	0	RW	Factory calibration data bits[11:4] of crosstalk measurement

Figure 75:
FACTORY_CALIB_2 Register

0x22: FACTORY_CALIB_2				
Field	Name	Reset	Type	Description
7:0	factory_calib_2	0	RW	Factory calibration data bits[19:12] of crosstalk measurement

Figure 76:
FACTORY_CALIB_3 Register

0x23: FACTORY_CALIB_3				
Field	Name	Reset	Type	Description
7:0	factory_calib_3	0	RW	Factory calibration data

Figure 77:
FACTORY_CALIB_4 Register

0x24: FACTORY_CALIB_4				
Field	Name	Reset	Type	Description
7:0	factory_calib_4	0	RW	Factory calibration data

Figure 78:
FACTORY_CALIB_5 Register

0x25: FACTORY_CALIB_5				
Field	Name	Reset	Type	Description
7:0	factory_calib_5	0	RW	Factory calibration data

Figure 79:
FACTORY_CALIB_6 Register

0x26: FACTORY_CALIB_6				
Field	Name	Reset	Type	Description
7:0	factory_calib_6	0	RW	Factory calibration data

Figure 80:
FACTORY_CALIB_7 Register

0x27: FACTORY_CALIB_7				
Field	Name	Reset	Type	Description
7:0	factory_calib_7	0	RW	Factory calibration data

Figure 81:
FACTORY_CALIB_8 Register

0x28: FACTORY_CALIB_8				
Field	Name	Reset	Type	Description
7:0	factory_calib_8	0	RW	Factory calibration data

Figure 82:
FACTORY_CALIB_9 Register

0x29: FACTORY_CALIB_9				
Field	Name	Reset	Type	Description
7:0	factory_calib_9	0	RW	Factory calibration data

Figure 83:
FACTORY_CALIB_10 Register

0x2a: FACTORY_CALIB_10				
Field	Name	Reset	Type	Description
7:0	factory_calib_10	0	RW	Factory calibration data

Figure 84:
FACTORY_CALIB_11 Register

0x2b: FACTORY_CALIB_11				
Field	Name	Reset	Type	Description
7:0	factory_calib_11	0	RW	Factory calibration data

Figure 85:
FACTORY_CALIB_12 Register

0x2c: FACTORY_CALIB_12				
Field	Name	Reset	Type	Description
7:0	factory_calib_12	0	RW	Factory calibration data

Figure 86:
FACTORY_CALIB_13 Register

0x2d: FACTORY_CALIB_13				
Field	Name	Reset	Type	Description
7:0	factory_calib_13	0	RW	Factory calibration data

If algorithm state data is sent to TMF8701 following registers shall be pre-loaded by the host before command=0x02 or 0x0B is executed.

Note(s): If only algorithm state data and no calibration data is sent to TMF8701, pre-load algorithm state data starting from address 0x20 instead of 0x2e.

Figure 87:
STATE_DATA_WR_0 Register

0x2e: STATE_DATA_WR_0				
Field	Name	Reset	Type	Description
7:0	state_data_wr_0	0	RW	Algorithm state data

Figure 88:
STATE_DATA_WR_1 Register

0x2f: STATE_DATA_WR_1				
Field	Name	Reset	Type	Description
7:0	state_data_wr_1	0	RW	Algorithm state data

Figure 89:
STATE_DATA_WR_2 Register

0x30: STATE_DATA_WR_2				
Field	Name	Reset	Type	Description
7:0	state_data_wr_2	0	RW	Algorithm state data

Figure 90:
STATE_DATA_WR_3 Register

0x31: STATE_DATA_WR_3				
Field	Name	Reset	Type	Description
7:0	state_data_wr_3	0	RW	Algorithm state data

Figure 91:
STATE_DATA_WR_4 Register

0x32: STATE_DATA_WR_4				
Field	Name	Reset	Type	Description
7:0	state_data_wr_4	0	RW	Algorithm state data

Figure 92:
STATE_DATA_WR_5 Register

0x33: STATE_DATA_WR_5				
Field	Name	Reset	Type	Description
7:0	state_data_wr_5	0	RW	Algorithm state data

Figure 93:
STATE_DATA_WR_6 Register

0x34: STATE_DATA_WR_6				
Field	Name	Reset	Type	Description
7:0	state_data_wr_6	0	RW	Algorithm state data

Figure 94:
STATE_DATA_WR_7 Register

0x35: STATE_DATA_WR_7				
Field	Name	Reset	Type	Description
7:0	state_data_wr_7	0	RW	Algorithm state data

Figure 95:
STATE_DATA_WR_8 Register

0x36: STATE_DATA_WR_8				
Field	Name	Reset	Type	Description
7:0	state_data_wr_8	0	RW	Algorithm state data

Figure 96:
STATE_DATA_WR_9 Register

0x37: STATE_DATA_WR_9				
Field	Name	Reset	Type	Description
7:0	state_data_wr_9	0	RW	Algorithm state data

Figure 97:
STATE_DATA_WR_10 Register

0x38: STATE_DATA_WR_10				
Field	Name	Reset	Type	Description
7:0	state_data_wr_10	0	RW	Algorithm state data

**Raw Histogram Output – If Register
register_contents= 0x80 ...0x93**

Figure 98:
HISTOGRAM_START Register

0x20: HISTOGRAM_START				
Field	Name	Reset	Type	Description
7:0	hist_start	0	RW	Quarter of histogram first byte

...all bytes until...

Figure 99:
HISTOGRAM_END Register

0x9f: HISTOGRAM_END				
Field	Name	Reset	Type	Description
7:0	hist_end	0	RW	Quarter of histogram last byte

**Serial Number Readout – If Register
register_contents=0x47**

Figure 100:
SERIAL_NUMBER_0 Register

0x28: SERIAL_NUMBER_0				
Field	Name	Reset	Type	Description
7:0	serial_number_0	0	RW	Serial number byte 0

Figure 101:
SERIAL_NUMBER_1 Register

0x29: SERIAL_NUMBER_1				
Field	Name	Reset	Type	Description
7:0	serial_number_1	0	RW	Serial number byte 1

Figure 102:
IDENTIFICATION_NUMBER_0 Register

0x2A: IDENTIFICATION_NUMBER_0				
Field	Name	Reset	Type	Description
7:0	identification_number_0	0	RW	Identification number byte 0

Figure 103:
IDENTIFICATION_NUMBER_1 Register

0x2B: IDENTIFICATION_NUMBER_1				
Field	Name	Reset	Type	Description
7:0	identification_number_1	0	RW	Identification number byte 1

The binary concatenated number of serial_number_0: serial_number_1:identification_number_0:identification_number_1 registers result in a unique number.

Bootloader Registers – appid=0x80

Following registers are only available if appid=0x80 (Bootloader):

Figure 104:
BL_CMD_STAT Register

0x08: BL_CMD_STAT				
Field	Name	Reset	Type	Description
7:0	bl_cmd_stat	0	RW	Write: Bootloader Command – see section Bootloader commands Read: Bootloader Status – anything else than 0x00 means an error

Figure 105:
BL_SIZE Register

0x09: BL_SIZE				
Field	Name	Reset	Type	Description
6:0	bl_size	0	RW	Data size in bytes

Figure 106:
BL_DATA Register

0x0A - 0x8A: BL_DATA				
Field	Name	Reset	Type	Description
7:0	bl_data0 ... bl_data127	0	RW	Up to 128 data bytes for bootloader commands

Figure 107:
BL_CSUM Register

0x8B: BL_CSUM				
Field	Name	Reset	Type	Description
7:0	bl_csum	0	RW	Checksum for Sum (Command + Data Size + Data itself) XOR 0xFF

Bootloader Commands

The following commands (bl_cmd_stat) are supported by the bootloader:

Figure 108:
Bootloader Commands

Commands	Value	Meaning
RAMREMAP_RESET	0x11	Remap RAM to address 0 and reset
DOWNLOAD_INIT	0x14	Initialize for RAM download from host to TMF8701
W_RAM	0x41	Write RAM region (Plain = not encoded into e.g. Intel Hex Records)
ADDR_RAM	0x43	Set the read/write RAM pointer to a given address

RAMREMAP_RESET = Execute Program Downloaded to RAM

This command remaps the RAM to address 0 and performs a System reset (see also command RESET).

Command is performed immediately without any delay.

After this the application that is located in RAM will be running. If there is no valid application you will need to do a HW reset (toggle enable pin or power cycle).

Figure 109:
RAMREMAP_RESET Command

Address	Value	Meaning
BL_CMD_STAT	0x11	REMAP RAM to 0 and RESET
BL_SIZE	0	No parameters
BL_CSUM	0xEE	

DOWNLOAD_INIT

This command is used to initialize the download HW for secure devices.

Figure 110:
DOWNLOAD_INIT Command

Address	Value	Meaning
BL_CMD_STAT	0x14	Initialize the HW for download from host to TMF8701 RAM
BL_SIZE	1	
BL_DATA0	0..0xFF	Seed
BL_CSUM	0..0xFF	

W_RAM

This command writes the given data to a defined RAM region. Note that the RAM pointer has first to be set by the command ADDR_RAM. After the command is successfully executed the RAM pointer will point to the first byte after the written region.

Figure 111:
W_RAM Command

Address	Value	Meaning
BL_CMD_STAT	0x41	Write to main RAM
BL_SIZE	0... 0x80	Number of bytes to be written
BL_DATA0	0..0xFF	1 st byte to be written
BL_DATA1	0..0xFF	2 nd byte to be written
...		
BL_DATA127	0..0xFF	128 th byte to be written (only if size was 0x80)
BL_CSUM	0..0xFF	The CSUM comes immediately after the data.

ADDR_RAM

This command is to specify the RAM pointer location for the next R_RAM or W_RAM command.

Figure 112:
ADDR_RAM Command

Address	Value	Meaning
BL_CMD_STAT	0x43	Specify the address of the next RAM read or write.
BL_SIZE	2	
BL_DATA0	0... 0xFF	LSB of address in RAM
BL_DATA1	0... 0xFF	MSB of address in RAM
BL_CSUM	0... 0xFF	

Application Information

SPAD Options

Signal SPADs

Firmware can enable/disable SPADs in the array as needed.

Figure 113:
Signal SPADs

	Min	Typ	Max	Comments
1x SPADS			72	
10x Attenuated SPADs			16	
100x Attenuated SPADs			16	

Physically there are $4 \times 32 = 128$ signal SPADs, but SPADs with too high dark count rate are disabled during production test. There are four TDCs (TDC1 ... TDC4) connected to the output of the SPADs. Each of the TDCs is connected to an array of 32 SPADs (SPADs with too high dark count rate are disabled). In distance mode the number of SPADs are reduced to typ. 40 SPADs to limit the FOV of the TMF8701.

Reference SPADs

Figure 114:
Reference SPADs

	Min	Typ	Max	Comments
100x Attenuated SPADs			9	

Due to the high light intensity from the VCSEL which is located very close to the reference SPADs and has no optical barrier like the signal SPADs only highly attenuated SPADs are used. Physically there are 12 reference SPADs, but SPADs with too high dark count rate are disabled during production test. There is one TDC (TDC0) connected to the output of the SPADs.

Reference SPAD, TDC and Histogram

There is an internal reference SPAD with associated TDC and histogram. This is used to determine the start time of each pulse. The reference SPAD is processed during calibration. The reference channel processing occurs internal to the device with no user interaction required.

All histograms can be processed inside the TMF8701 and/or readout through the I²C interface. As the readout is constrained by the I²C speed and the I²C bus utilization (TMF8701 can support I²C speed up to 1MHz), it is recommended to readout the histograms only for debugging purposes.

Figure 115 shows a histogram obtained from TMF8701. The x-axis is scaled in bins, and the nominal bin size is 100ps per bin and each TDC has 256 bins. The y-axis is scaled in counts represented by 16 bits values. The green line shows the reference histogram from TDC0 and its peak marks the reference or zero distance. The other four lines (blue, cyan, red and violet) are the histograms obtained from TDC1 to TDC4. A target at 20cm is used to generate the peak around bin 25.

Figure 115:
Histogram

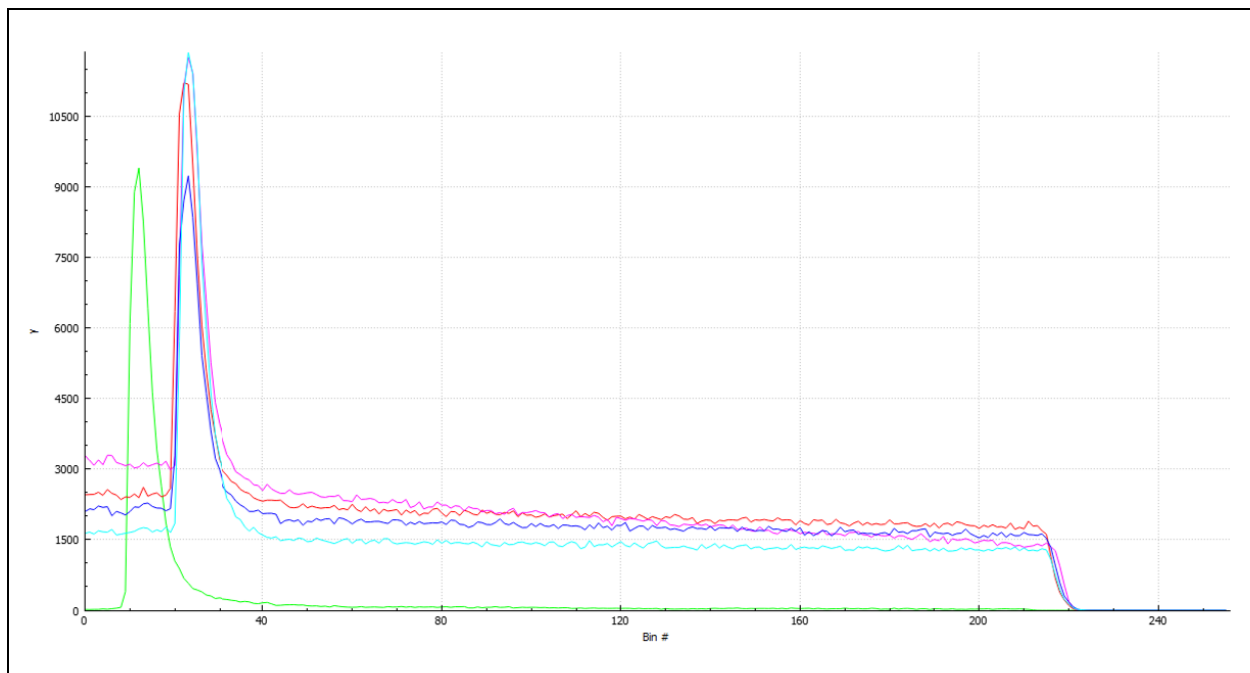

Schematic

The TMF8701 needs only 3 small 0402 external capacitors for operation:

Figure 116:
TMF8701 Application Schematic

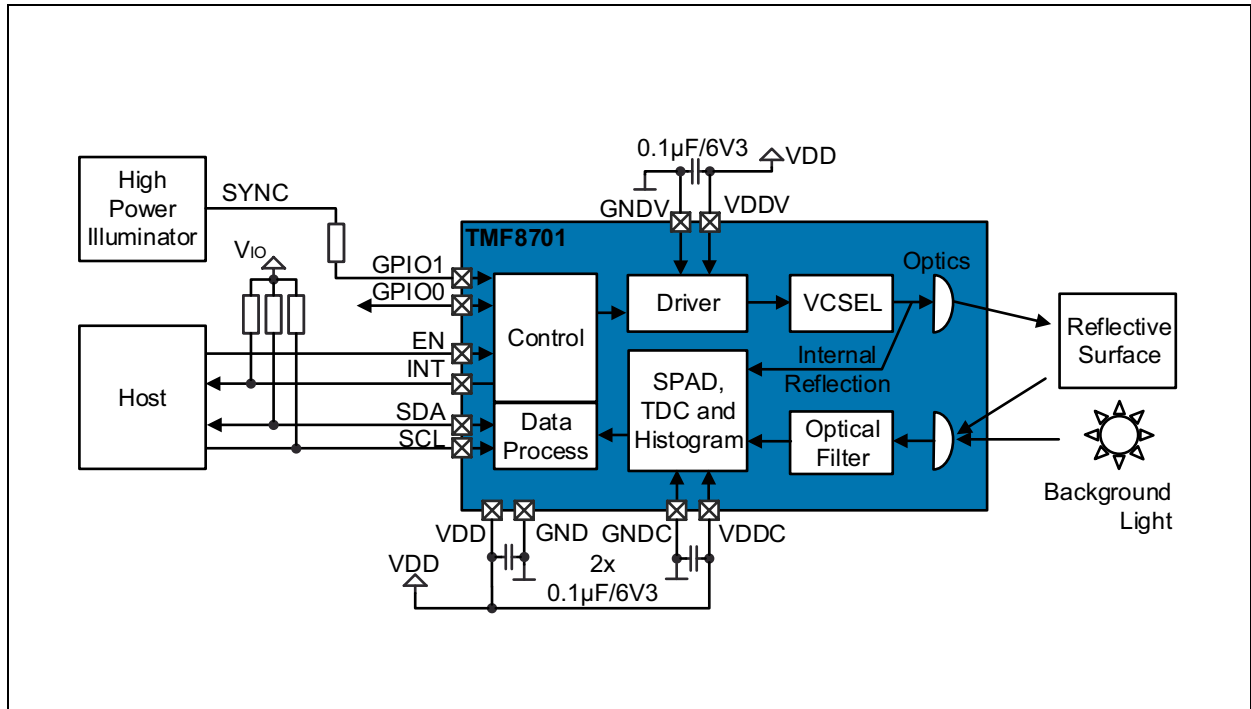

The SYNC signal connected to GPIO1 can be used to immediately interrupt the TMF8701 VCSEL operation if the high power illuminator is operating. It needs to be ensured that SYNC does not exceed the VDD supply of TMF8701 as otherwise an internal protection diode will start conducting. The VCSEL operation is controlled by setting cmd_data5 of command=0x02 or 0x03 according (see [App0 Registers – appid=0xC0](#) registers). On SYNC assertion, the VCSEL is immediately switched off (typically after 10µs), on SYNC de-assertion the VCSEL operation is resumed within >100µs. GPIO0 can be used as a general GPIO output signal. The signals INT/SDA/SCL need an external pullup resistor to the V_{IO} supply (typically 1.8V).

PCB Layout

Figure 117:
PCB Layout Recommendation

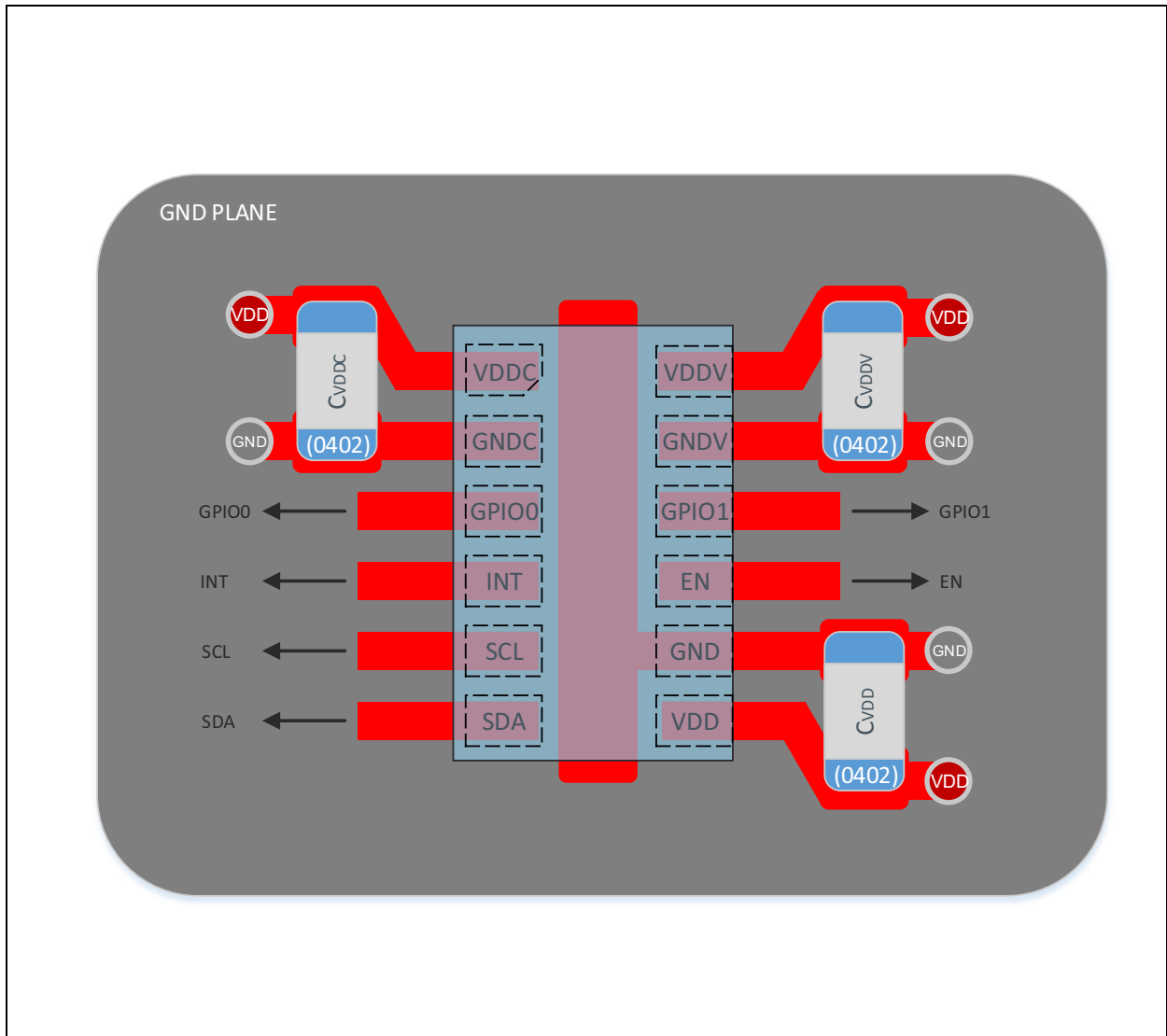

Use GRM155R70J104KA01 (0402 X7R 0.1 μ F 6.3V) or capacitors with same or better performance for C_{VDDC}, C_{VDD} and C_{VDDV}.

PCB Pad Layout

Figure 118:
PCB Pad Layout

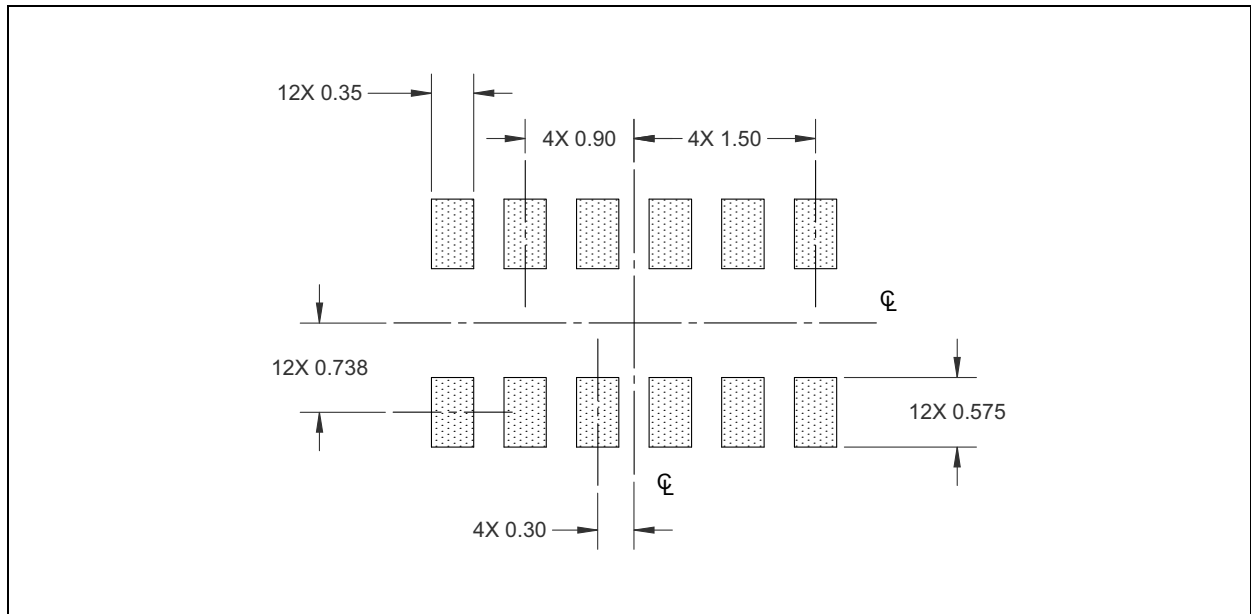

Note(s):

1. All linear dimensions are in millimeters.
2. Dimension tolerances are 0.05mm unless otherwise noted.
3. This drawing is subject to change without notice.

Use the PCB pad layout as a recommendation only. The actual pad layout shall be optimized for the customer production line.

Package Information

Figure 119:
Package Drawing

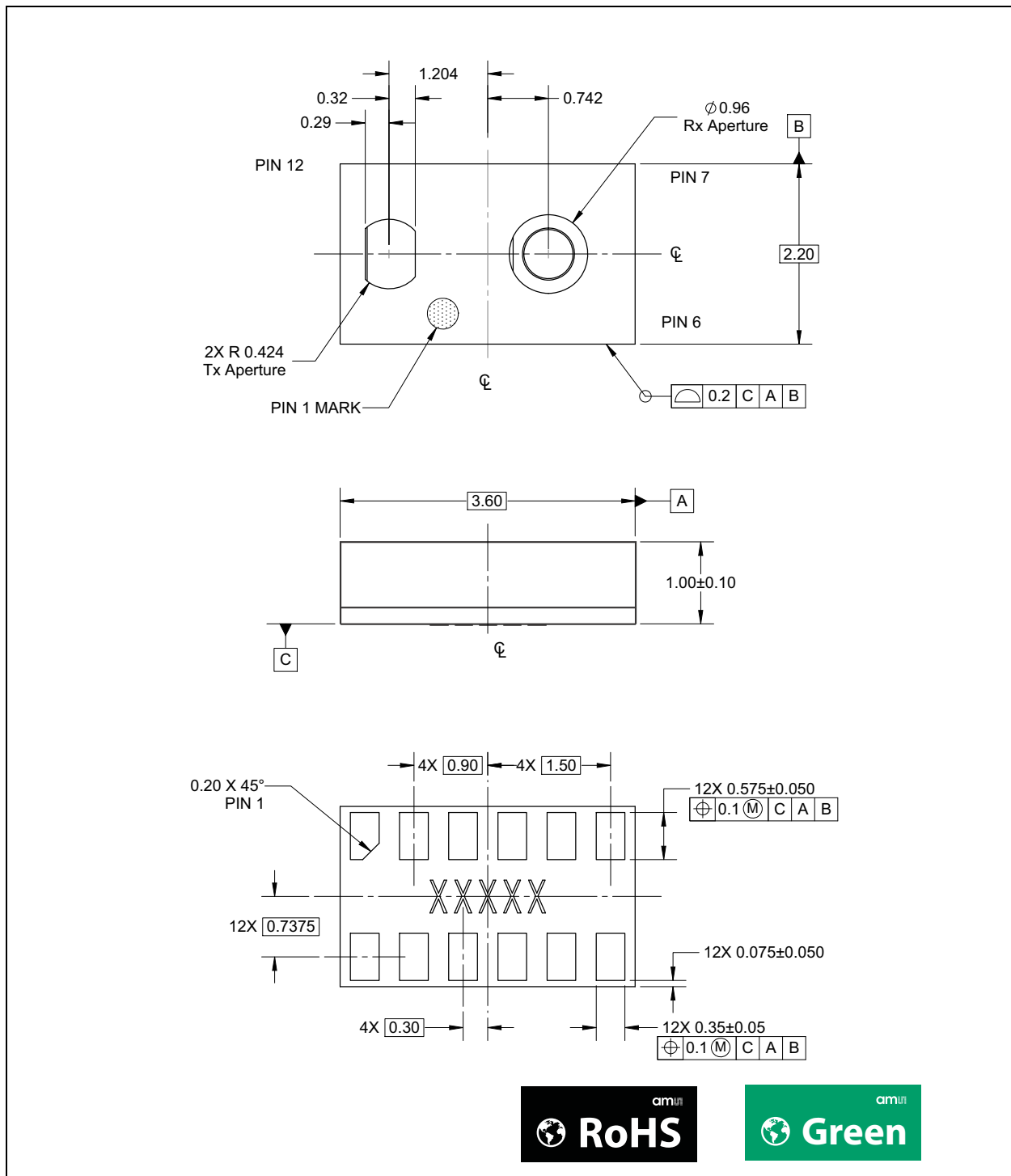

Note(s):

1. All linear dimensions are in millimeters.
2. Contact finish is Au/Ni
3. This package contains no lead (Pb).
4. This drawing is subject to change without notice.
5. 5-digit tracecode is only on bottom side of the package.

Tape & Reel Information

Figure 120:
Tape and Reel Drawing

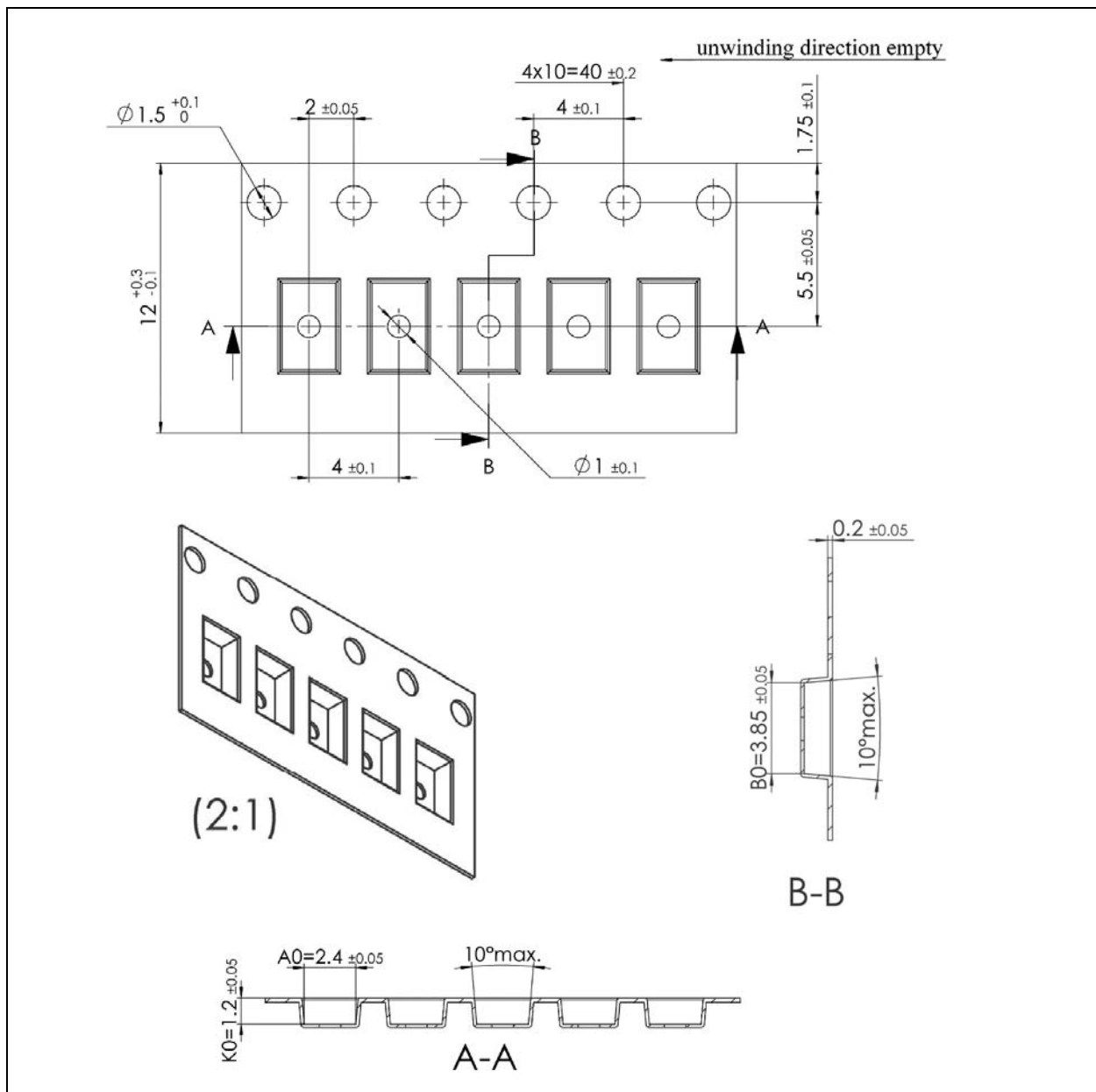

Note(s):

1. All linear dimensions are in millimeters. Dimension tolerance is ± 0.10 mm unless otherwise noted.
2. The dimensions on this drawing are for illustrative purposes only. Dimensions of an actual carrier may vary slightly.
3. Symbols on drawing A0, B0, and K0 are defined in ANSI EIA Standard 481-B 2001.
4. There are two reel sizes available (see section [Ordering Information](#))
 - a. 7" reels: Each reel is 7 inches in diameter and contains 500 parts.
 - b. 13" reels: Each reel is 13 inches in diameter and contains 5000 parts.
5. **ams** packaging tape and reel conform to the requirements of EIA Standard 481-B.
6. In accordance with EIA standard, device pin 1 is located next to sprocket holes in the tape.
7. This drawing is subject to change without notice.

Soldering & Storage Information

Soldering Information

The package has been tested and has demonstrated an ability to be reflow soldered to a PCB substrate. The process, equipment, and materials used in these test are detailed below.

The solder reflow profile describes the expected maximum heat exposure of components during the solder reflow process of product on a PCB. Temperature is measured on top of component. The components should be limited to a maximum of three passes through this solder reflow profile.

Figure 121:
Solder Reflow Profile Graph

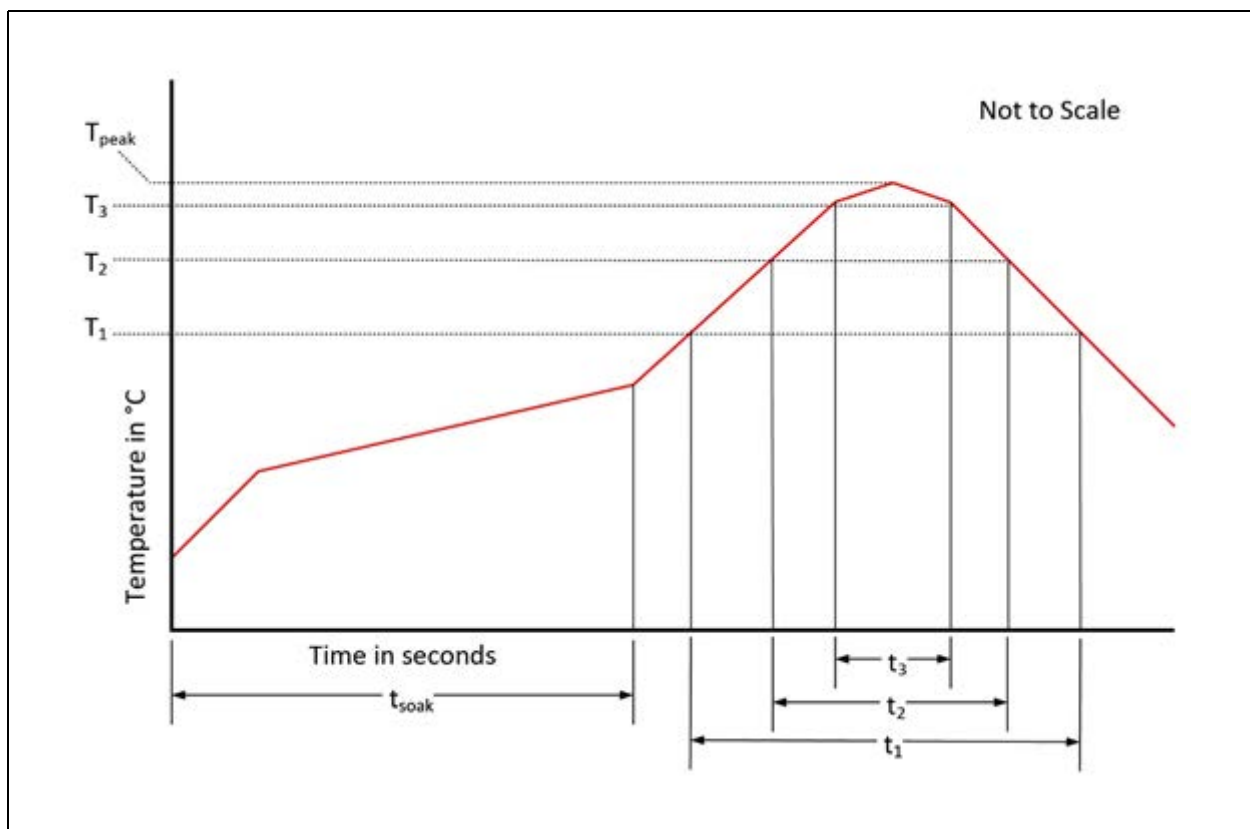

Figure 122:
Solder Reflow Profile

Parameter	Reference	Device
Average temperature gradient in preheating		2.5°C/s
Soak time	t_{soak}	2 to 3 minutes
Time above 217 °C (T1)	t1	Max 60s
Time above 230 °C (T2)	t2	Max 50s
Time above $T_{\text{peak}} - 10$ °C (T3)	t3	Max 10s
Peak temperature in reflow	T_{peak}	260°C
Temperature gradient in cooling		Max -5°C/s

Storage Information

Moisture Sensitivity

Optical characteristics of the device can be adversely affected during the soldering process by the release and vaporization of moisture that has been previously absorbed into the package.

To ensure the package contains the smallest amount of absorbed moisture possible, each device is baked prior to being dry packed for shipping. Devices are dry packed in a sealed aluminized envelope called a moisture-barrier bag with silica gel to protect them from ambient moisture during shipping, handling, and storage before use.

Shelf Life

The calculated shelf life of the device in an unopened moisture barrier bag is 12 months from the date code on the bag when stored under the following conditions:

- Shelf Life: 12 months
- Ambient Temperature: <40°C
- Relative Humidity: <90%

Rebaking of the devices will be required if the devices exceed the 12 month shelf life or the Humidity Indicator Card shows that the devices were exposed to conditions beyond the allowable moisture region.

Floor Life

The module has been assigned a moisture sensitivity level of MSL 3. As a result, the floor life of devices removed from the moisture barrier bag is 168 hours from the time the bag was opened, provided that the devices are stored under the following conditions:

- Floor Life: 168 hours
- Ambient Temperature: <30°C
- Relative Humidity: <60%

If the floor life or the temperature/humidity conditions have been exceeded, the devices must be rebaked prior to solder reflow or dry packing.

Rebaking Instructions

When the shelf life or floor life limits have been exceeded, rebake at 50°C for 12 hours.

Laser Eye Safety

The TMF8701 is designed to meet the Class 1 laser safety limits including single faults in compliance with IEC/EN 60825-1:2014 and IEC/EN 60825-1:2007. This applies to the stand-alone device and the included software supplied by **ams**. In an end application system environment, the system may need to be tested to ensure it remains compliant. The system must not include any additional lens to concentrate the laser light or parameters set outside of the recommended operating conditions. Use outside of the recommended condition or any physical modification to the module during development could result in hazardous levels of radiation exposure.



Additionally the device has been measured according to IEC/EN 60825-1:2007 and it is classified as class 1 according to this standard as well:



Ordering & Contact Information

Figure 123:
Ordering Information

Ordering Code	Package	Marking	Delivery Form	Delivery Quantity
TMF8701-1XM	Optical Module	5-Digit Tracecode (coded)	Tape & Reel (7")	500 parts/reel
TMF8701-1X			Tape & Reel (13")	5000 parts/reel

Note(s):

1. Where X=ROM version (A-Z).

Buy our products or get free samples online at:

www.ams.com/Products

Technical Support is available at:

www.ams.com/Technical-Support

Provide feedback about this document at:

www.ams.com/Document-Feedback

For further information and requests, e-mail us at:

ams_sales@ams.com

For sales offices, distributors and representatives, please visit:

www.ams.com/Contact

Headquarters

ams AG
Tobelbader Strasse 30
8141 Premstaetten
Austria, Europe

Tel: +43 (0) 3136 500 0

Website: www.ams.com

RoHS Compliant & ams Green Statement

RoHS: The term RoHS compliant means that ams AG products fully comply with current RoHS directives. Our semiconductor products do not contain any chemicals for all 6 substance categories plus additional 4 substance categories (per amendment EU 2015/863), including the requirement that lead not exceed 0.1% by weight in homogeneous materials. Where designed to be soldered at high temperatures, RoHS compliant products are suitable for use in specified lead-free processes.

ams Green (RoHS compliant and no Sb/Br/Cl): ams Green defines that in addition to RoHS compliance, our products are free of Bromine (Br) and Antimony (Sb) based flame retardants (Br or Sb do not exceed 0.1% by weight in homogeneous material) and do not contain Chlorine (Cl not exceed 0.1% by weight in homogeneous material).

Important Information: The information provided in this statement represents ams AG knowledge and belief as of the date that it is provided. ams AG bases its knowledge and belief on information provided by third parties, and makes no representation or warranty as to the accuracy of such information. Efforts are underway to better integrate information from third parties. ams AG has taken and continues to take reasonable steps to provide representative and accurate information but may not have conducted destructive testing or chemical analysis on incoming materials and chemicals. ams AG and ams AG suppliers consider certain information to be proprietary, and thus CAS numbers and other limited information may not be available for release.

Copyrights & Disclaimer

Copyright ams AG, Tobelbader Strasse 30, 8141 Premstaetten, Austria-Europe. Trademarks Registered. All rights reserved. The material herein may not be reproduced, adapted, merged, translated, stored, or used without the prior written consent of the copyright owner.

Devices sold by ams AG are covered by the warranty and patent indemnification provisions appearing in its General Terms of Trade. ams AG makes no warranty, express, statutory, implied, or by description regarding the information set forth herein. ams AG reserves the right to change specifications and prices at any time and without notice. Therefore, prior to designing this product into a system, it is necessary to check with ams AG for current information. This product is intended for use in commercial applications. Applications requiring extended temperature range, unusual environmental requirements, or high reliability applications, such as military, medical life-support or life-sustaining equipment are specifically not recommended without additional processing by ams AG for each application. This product is provided by ams AG "AS IS" and any express or implied warranties, including, but not limited to the implied warranties of merchantability and fitness for a particular purpose are disclaimed.

ams AG shall not be liable to recipient or any third party for any damages, including but not limited to personal injury, property damage, loss of profits, loss of use, interruption of business or indirect, special, incidental or consequential damages, of any kind, in connection with or arising out of the furnishing, performance or use of the technical data herein. No obligation or liability to recipient or any third party shall arise or flow out of ams AG rendering of technical or other services.

Document Status

Document Status	Product Status	Definition
Product Preview	Pre-Development	Information in this datasheet is based on product ideas in the planning phase of development. All specifications are design goals without any warranty and are subject to change without notice
Preliminary Datasheet	Pre-Production	Information in this datasheet is based on products in the design, validation or qualification phase of development. The performance and parameters shown in this document are preliminary without any warranty and are subject to change without notice
Datasheet	Production	Information in this datasheet is based on products in ramp-up to full production or full production which conform to specifications in accordance with the terms of ams AG standard warranty as given in the General Terms of Trade
Datasheet (discontinued)	Discontinued	Information in this datasheet is based on products which conform to specifications in accordance with the terms of ams AG standard warranty as given in the General Terms of Trade, but these products have been superseded and should not be used for new designs

Revision Information

Changes from 1-06 (2019-Feb-08) to current revision 1-07 (2020-Apr-28)	Page
Removed "Confidential" from the footer	
Updated Typical Operating Characteristics	17
Updated INT_STATUS Register (0xe1)	19
Updated INT_ENAB Register (0xe2)	20
Added "Soldering Information" section	55

Note(s):

1. Page and figure numbers for the previous version may differ from page and figure numbers in the current revision.
2. Correction of typographical errors is not explicitly mentioned.

Content Guide

1	General Description
1	Key Benefits & Features
2	Applications
2	Block Diagram
3	Pin Assignments
3	Pin Diagram
3	Pin Description
5	Absolute Maximum Ratings
7	Electrical Characteristics
7	Recommended Operating Conditions
8	Typical Operating Characteristics
10	Detailed Description
10	I ² C Protocol
11	TOF Description
11	System Parameters
11	I/O
12	Power Consumption
13	Timing
13	<i>Ranging Acquisition Timing</i>
14	<i>Reset Pin and Power-Up Timing</i>
14	Distance and Proximity Algorithm
14	<i>Calibration</i>
14	<i>Operating Modes and Timings</i>
15	<i>Proximity Mode</i>
16	<i>Proximity and Distance Mode Combined</i>
16	VCSEL
17	Typical Optical Characteristics
17	<i>Filter Characteristics</i>
18	Register Description
18	Register Overview
21	App0 Registers – appid=0xC0
29	Object Detection Results – If Register register_contents = 0x55 (Commands 0x02, 0x03 or 0x04)
36	Calibration and Algorithm State Data Exchange
42	Raw Histogram Output – If Register register_contents = 0x80 ... 0x93
43	Serial Number Readout – If Register register_contents = 0x47
44	Bootloader Registers – appid=0x80
45	Bootloader Commands
45	<i>RAMREMAP_RESET = Execute Program Downloaded to RAM</i>
46	<i>DOWNLOAD_INIT</i>
46	<i>W_RAM</i>
47	<i>ADDR_RAM</i>

48	Application Information
48	SPAD Options
48	Signal SPADs
48	Reference SPADs
49	Reference SPAD, TDC and Histogram
50	Schematic
51	PCB Layout
52	PCB Pad Layout
53	Package Information
54	Tape & Reel Information
55	Soldering & Storage Information
55	Soldering Information
56	Storage Information
56	Moisture Sensitivity
56	Shelf Life
57	Floor Life
57	Rebaking Instructions
58	Laser Eye Safety
59	Ordering & Contact Information
60	RoHS Compliant & ams Green Statement
61	Copyrights & Disclaimer
62	Document Status
63	Revision Information